



Y Center Latch Elevator Operation Manual

<i>Document Number</i>		
OM002		
<i>REV</i>	B	06/10/2024

© 2005-2022 Texas International Oilfield Tools, LTD.
Published by Texas International Oilfield Tools, LTD
3035 Eastveld Dr • Houston, TX 77073
www.texasinternational.com

CONFIDENTIALITY STATEMENT

This document contains confidential information. All rights including copyright, confidential information, trade secrets and design rights are owned by Texas International Oilfield Tools, LTD (TIOT, Texas International, and Texas International Oilfield Tools). No use or disclosure is to be made without prior written permission of Texas International Oilfield Tools, LTD.

Revision History

Rev	Date	Reason
A	10/15/14	Issued for Use

Description of Change

Rev	Change
A	-

TABLE OF CONTENTS

GENERAL	4
CONVENTIONS	5
SAFETY	5
SPECIFICATIONS	5
ACCESSORIES	6
SLIP INSTALLATION/REMOVAL	7
PREVENTIVE MAINTENANCE	8
ELEVATOR WEAR LIMITS	11
CRITICAL AREA MAP	12
TROUBLESHOOTING	12
STORAGE AND TRANSPORTATION	13
SPARE PARTS LIST.....	14

GENERAL



Figure 1 – HYC 200 ton elevator

Texas International Oilfield Tools (TIOT) offers “Y” center latch, slip type manual elevators for tubing (YT, MYT) and casing (YC, HYC, MYC). See Specification table on page 5 for load capacity and size ranges. The elevators hoist a variety of small casing and tubing with the proper size slips and slip setting ring installed. The slips are easily changed. The elevator is designed with two (2) halves of similar weights for good balance and easier opening and closing. A guarded operating latch and an extra handle at the rear of the elevator allow for easier, safer operation. Elevators are equipped with a latch and latch lock combination. To open, pull the latch lock handle out and swing the elevator apart. The latch and latch lock secures automatically when the elevator is closed around the pipe. The load causes the slips to set when the elevator is raised, pushing down on the slip setting ring.



Ensure all slip inserts are free in the up position when latching the elevator



Use the ears for lifting elevator – NOT the rear handle.

CONVENTIONS



IMPORTANT SYMBOL IDENTIFICATION	
	WARNING to Operators / Users
	CAUTION to Operators / Users
	NOTIFICATION to Operators / Users

Table 1

SAFETY

Texas International's equipment is used and installed in controlled rig environments involving hazardous operations and situations.

All personnel performing installation, operations, repair or maintenance on this elevator must have knowledge of rig procedure. All crew in the vicinity of operations should be trained on rig safety and tool operation.

SPECIFICATIONS

Size Range	Part		Capacity
	Number	Model	(Tons)
3-1/2" - 7-5/8"	T55310	HYC	200
3-1/2" - 7"	T200360	MYC	125
3-1/2" - 7"	T24140	YC	75
1.315" - 3-1/2"	T55600	YT	75
1.315" - 2-7/8"	T29238	MYT	40

Table 2

ACCESSORIES

Description		SLIP ASSEMBLY	SLIP BODY	INSERT	SPACER	INSERT RETAINER	SLIP SETTING RING	GUIDE PLATE
SLIP SIZE	PIPE SIZE							
HYC- Frame T55310 - 200 Ton - Casing Elevator Weight=991 Lbs*								
4 1/2" x 3 1/2"		T55509	T55303	24779		T30214	T55516	T26827-1
4 1/2" x 4"		T55510	T55303	24781		T30214	T55517	T26827
4 1/2"		T55511	T55303	16408		T30214	T55518	T24071-4
5 1/2" x 5"		T55512	T55304	24783		T30221	T55519	T24071
5 1/2"		T55513	T55304	16407		T30224	T55520	T24071-1
7" x 6 5/8"		T55514	T55305	24748		T30227	T55521	T24071-3
7"		T55515	T55305	16407		T30230	T55522	T24071-2
7 5/8"		T70009	T56305-1	70010		T70011	T70012	T24071-6
MYC - Frame T200360 -125 Tons - Casing Elevator Weight=610 Lbs*								
4 1/2" x 4"		T26830	T24072-4	24781	T24506	T30214	T30209	T26827
4 1/2"		T24072-5	T24072-4	16408	T24506	T30214	T30219	T24071-4
5 1/2" x 5"		T24072-7	T24072	24783	T24506	T30221	T30220	T24071
5 1/2"		T24072-2	T24072	16407	T24506	T30224	T30223	T24071-1
7" x 6 5/8"		T24077-7	T24077	24748	T24506	T30227	T30226	T24071-3
7"		T24077-1	T24077	16407	T24506	T30230	T30229	T24071-2
YC - Frame T24140 - 75 Tons - Casing Elevator Weight=442 Lbs*								
4-1/2"		T24072-5	T24072-4	16408	T24506	T30214	T30219	T24071-4
5-1/2" x 5"		T24072-7	T24072	24783	T24506	T30221	T30220	T24071
5-1/2"		T24072-2	T24072	16407	T24506	T30224	T30223	T24071-1
7" x 6-5/8"		T24077-7	T24077	24748	T24506	T30227	T30226	T24071-3
7"		T24077-1	T24077	16407	T24506	T30230	T30229	T24071-2
MYT - Frame T29328 - 40 Tons - Tubing Weight=140 Lbs*								
2-1/16 x 1.315"		T29343-7	T29343-10	29259		T29344	T29354	
2-1/16 x 1.660"		T29343-6	T29343-10	29258		T29344	T29353	
2-1/16 x 1.900"		T29343-5	T29343-10	29257		T29344	T29352	
2-1/16 x 2"		T29343-4	T29343-10	29256		T29344	T29351	
2-1/16"		T29343-3	T29343-10	29256		T29344	T29350	
2-7/8 x 2-3/8"		T29343-2	T29343-10	29255		T29344	T29345	
2-7/8"		T29343-1	T29343-10	24773		T29344	T29348	

Description		SLIP ASSEMBLY	SLIP BODY	INSERT	SPACER	INSERT RETAINER	SLIP SETTING RING	GUIDE PLATE
SLIP SIZE	PIPE SIZE							
YT - Frame T55600 - 75 Tons - Tubing Weight=345 Lbs*								
2-7/8 x 1.315"		T23108-11	T23108-2	29259	T24508	T27451	T29001	
2-7/8 x 1.600"		T23108-10	T23108-2	29258	T24508	T27451	T27810	
2-7/8 x 1.900"		T23108-9	T23108-2	29257	T24508	T27451	T27811	
2-7/8 x 2"		T23108-8	T23108-2	29256	T24508	T27451	T27821	
2-7/8 x 2-1/16"		T23108-7	T23108-2	29256	T24508	T27451	T27812	
2-7/8 x 2-3/8"		T23108-6	T23108-2	29255	T24508	T27451	T27694	
2-7/8"		T23108-4	T23108-2	24773	T24508	T27451	T27695	
3-1/2"		T23108-5	T23108	24774	T24507	T27530	T27813	

Table 3

* Nominal weight of elevator only

SLIP INSTALLATION/REMOVAL

1. To install slips, TIOT suggests starting with slip #2 or slip #4 (see Figure 2). Unscrew slip bolt assembly at starting slip location and set bolt aside.



The slip spring may pop out – set back in its cavity

2. Holding the slip from the bottom with one hand, compress the spring using the hinge on the back of the slip and using the opposite palm, push slip under the elevator frame/edge. See Figure 3. Use a long screwdriver to secure the slip temporarily. Remove screwdriver and then reinstall the slip bolt assembly. Push slip down and release to verify free movement.



If slip does not move freely, remove and reinstall

3. Install the adjoining slip. The slip's side notch will fit into the side cavity.

Repeat steps 1 through 3 to install slips on the opposite side.

- 4a. On the body side, place the insert retainer on each slip.
- 4b. Set the setting ring on top of retainers. For the YT and YC series, put rubber bushings inside the setting ring's holes and place the setting ring retainers on top of the setting ring.

Slip Installation/Removal continued

- 4c. Install threaded bolts either into either the retainer (YT and YC series) or setting ring (MYT).
- 4d. Secure bolts with wire.
5. On opposite side, install insert retainers (see Figure 2) with bolts.
6. On YT model, install guide plate.

To remove slips, reverse steps above.

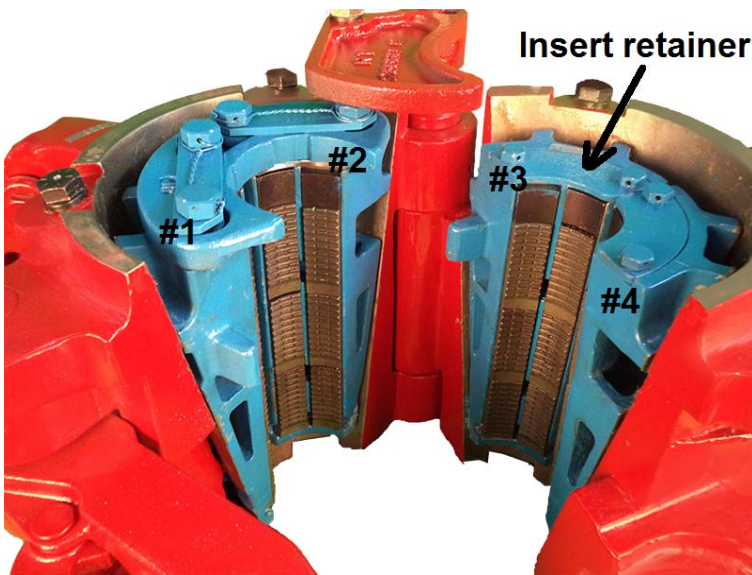

Figure 2 – YT 75 ton elevator with slips



Figure 3 – Compressing spring to install slip



TIOT recommends removing inserts after each use and coat insert slot with light machine oil.

PREVENTIVE MAINTENANCE



This is a suggested PM schedule. The tool owner has the responsibility to adjust the program according to actual tool usage



When there is suspicion that the elevator has been **overloaded**, it should be pulled from operation for an Annual type PM.

Normal wear in course of use will eventually reduce the elevator's capability. Inspect the latch, latch pin and hinge pin regularly for wear. Cracks or the appearance of damage can indicate the need for repair, even impending failure, and requires prompt attention. The elevator must be either pulled from operation immediately or repaired.

Daily (PM1) – While in use

- Apply EP 4 grease to grease port and ears, as needed
- Inspect the contact surface of the ears. If surfaces are flattened or metal is rolled, the elevator should be pulled from operation for Annual (PM3)
- Open and close the elevator 5 times slowly and 5 times quickly to ensure elevator works properly
- Press slips down and release - slips should come up if springs are operational
- Clean slip inserts and inspect for wear and missing teeth – if found, replace
- Visually check elevator for damage and cracks – if found, pull from operation for repair
- Look for worn, damaged, loose or missing parts – replace or tighten
- Verify retainer shoulder screws are Grade 8. If not, replace
- Check for wear on hinge pin by checking the vertical play between latch, body, and door
- Inspect tack welds (see Figure 5). On YC model elevator, check underside hinge pin and latch lock pin. On all other Y series, check latch lock pin. If broken, remove from operation and repair

Semi-Annual (PM2)

- Try to open the latch by prying the latch between body and latch with a steel bar or screw driver – the latch lock must prevent the latch from being opened (Figure 4). If the elevator opens during pry test, pull from operation for repair
- Check for corrosion and breakage on pins and springs – if found, replace
- Remove coating and debris from critical areas
- Disassemble and perform Magnetic Particle Inspection (MPI) on critical areas as indicated on API Specification 8C
- Carry on daily PM

Annual (PM3)

- Repeat daily and semi-annual PMs
- Performance load test
- MPI critical areas twenty four (24) hours after load test
- Repair cast as needed - recommend repairs be done by TIOT



Proof of load test and MPI are required after remanufacture or a major weld repair in a critical area

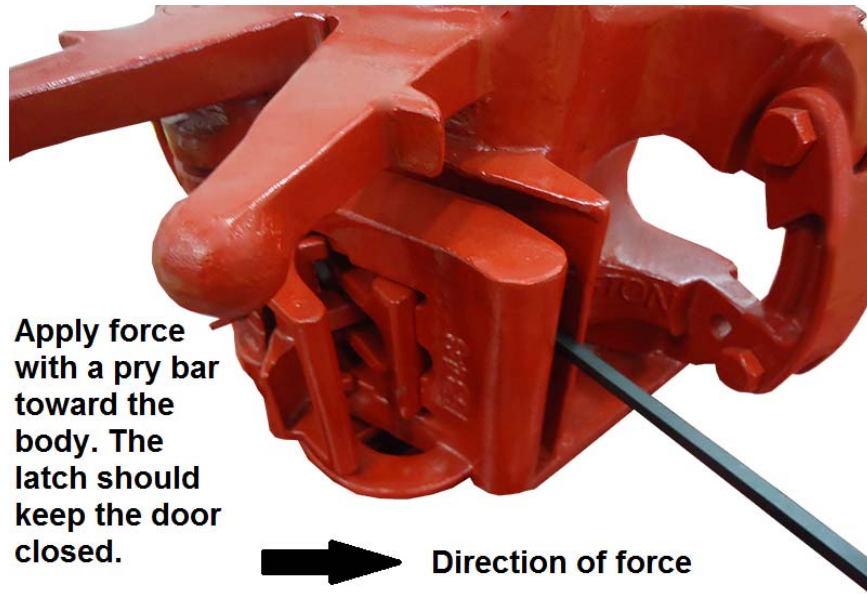

Figure 4 - Pry test Instructions



Figure 5 - YC tack welds

ELEVATOR WEAR LIMITS

The wear of the elevator affects its ability to support the required load. Elevators for which the ear measurements are lower than the minimum shown in Table 4 shall either be remanufactured or scrapped.

Ear Radius (R) <i>based on tons</i>	Minimum <i>in inches</i>
40	1 ¼
75	1 ¼
125	1 3/8
200	2

Table 4

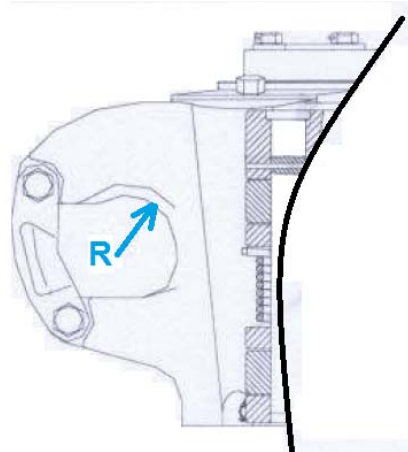

Figure 6

Model	HYC	MYC	YC	YT	MYT
Total Clearance					
Hinge Pin	0.045	0.040	0.035	0.030	0.025
Latch Pin	0.045	0.035	0.035	0.030	0.025

Table 5

CRITICAL AREA MAP

Darken areas are defined as critical

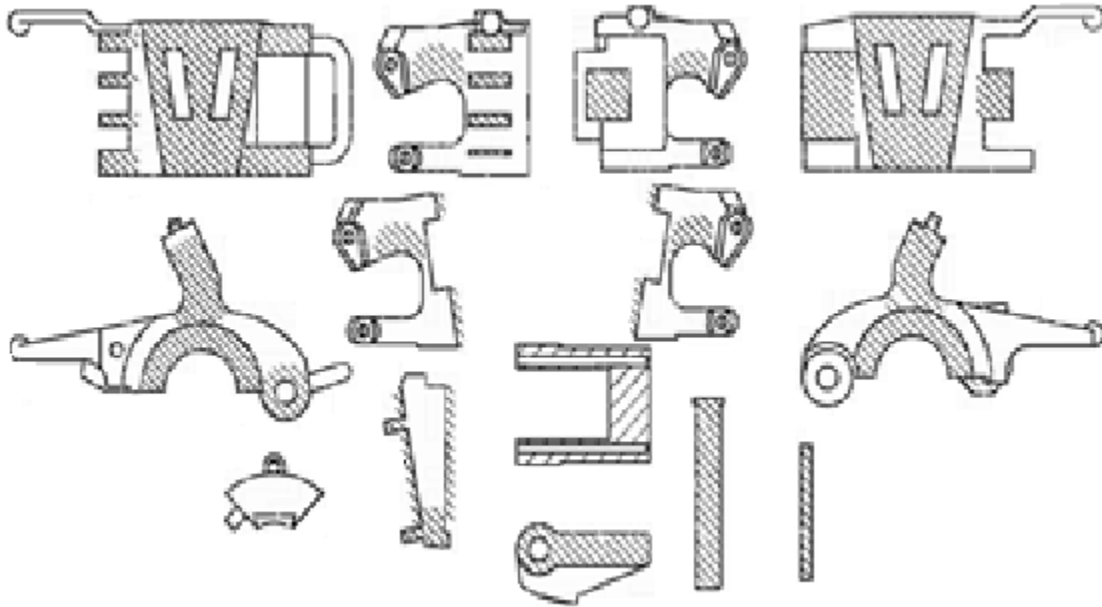

Figure 7

TROUBLESHOOTING

Failure Mode	Possible Cause	Possible Solution
Deformed pin holes	Overload	Scrap the tool Pull elevator from operation and carry on PM 3
	Wear	Verify pin clearance (see Table 5)
Bent pins	Overload	Perform PM 3
Elevator does not open	Corrosion	Pry open, clean and lubricate.
	Overload	Carry on PM 3 Scrap the tool
Elevator does not close	Oversized tubular	Select properly sized elevator
Elevator does not hang level	Link length	Use same length slings/links
Slips do not move freely	Spring	Incorrect spring installed - change
	Setting plate	Loosen bolts to remove bind
	Slip bolt	Verify bolt floats freely and correct size installed Check spacer/washer is installed

Table 6

STORAGE AND TRANSPORTATION

- Unpainted surfaces should be coated with rust preventing agent
- Prevent excessive exposure to water and moisture
- Clean the tool after use - steam clean as needed; remove mud, debris and any other substances
- Transport the unit on a suitable container or pallet

SPARE PARTS LIST

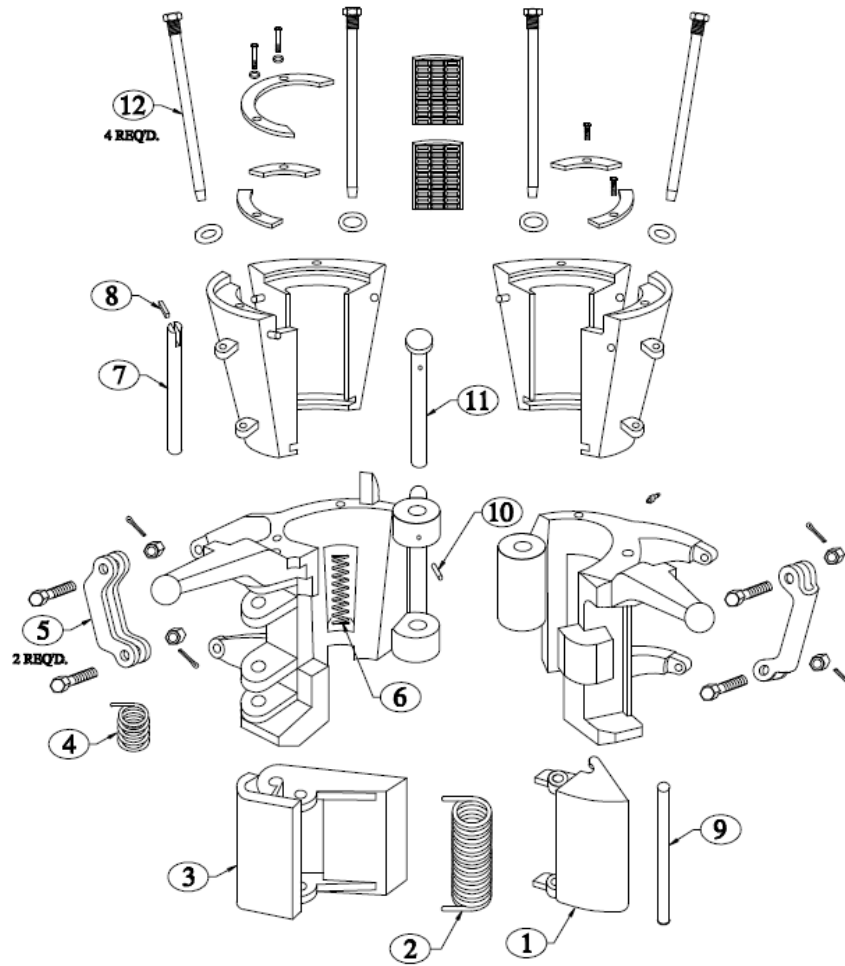

Figure 8 – MYT exploded

MYT Spare Parts List			
#	Component	Req	P/N
1	LATCH LOCK	1	T30653
2	LATCH LOCK SPRING	2	T29349
3	LATCH	1	T30652
4	LATCH SPRING	1	T29338
5	LINK BLOCK	2	T29337
6	SLIP SPRING	4	29340
7	LATCH PIN	2	T29334
8	LATCH LOCK PIN RETAINER	2	T947129-151
9	LATCH LOCK PIN	1	T29335
10	LATCH PIN RETAINER	2	T947129-238
11	HINGE PIN	1	T29333
12	SLIP BOLT	4	29336

Table 7

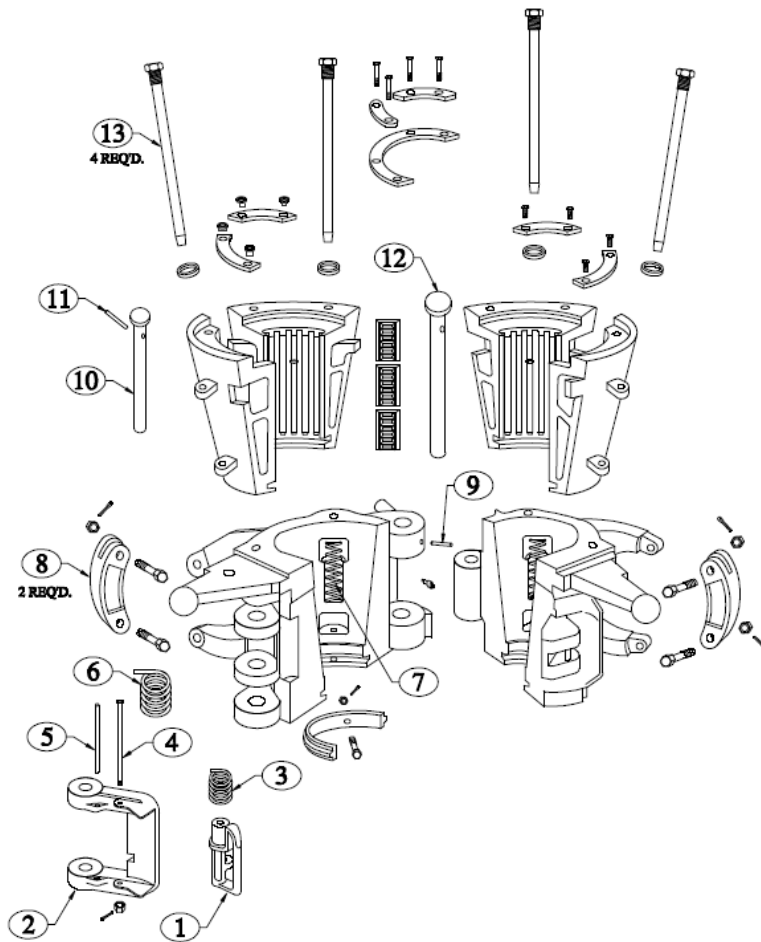

Figure 9 – YC Series exploded

SPARE PARTS LIST					
ELEVATOR MODEL >>>			HYC	MYC	YC
ITEM #	DESCRIPTION	QTY	PART NUMBER		
1	LATCH LOCK	1	T13152		T12972
2	LATCH	1	T55503	T200363	T15348
3	LATCH LOCK SPRING	2	T13188		N/A
4	LATCH LOCK PIN	1	N/A		T13530
4	LATCH LOCK BOLT	1	T15101	T200371	N/A
5	LATCH LOCK SPRING STOP	1	T13185-1	T200368	N/A
6	LATCH SPRING	1	T34909	T200367	T12978
7	SLIP SPRING	1	T945044-2	T24049	
8	LINK BLOCK	2	T9519		
9	HINGE PIN RETAINER	2	T55504	T36901-1	N/A
10	LATCH PIN	2	T55312	T200365	T24182
11	LATCH PIN RETAINER	2	T55505	T36951-1	T29448
12	HINGE PIN	1	T55311	T200364	T24181
13	SLIP BOLT ASSEMBLY	4	T50003697-2		
14 **	LATCH CAM	1	N/A	N/A	T12008

** NOT SHOWN

TABLE 8

Spare Parts List continued

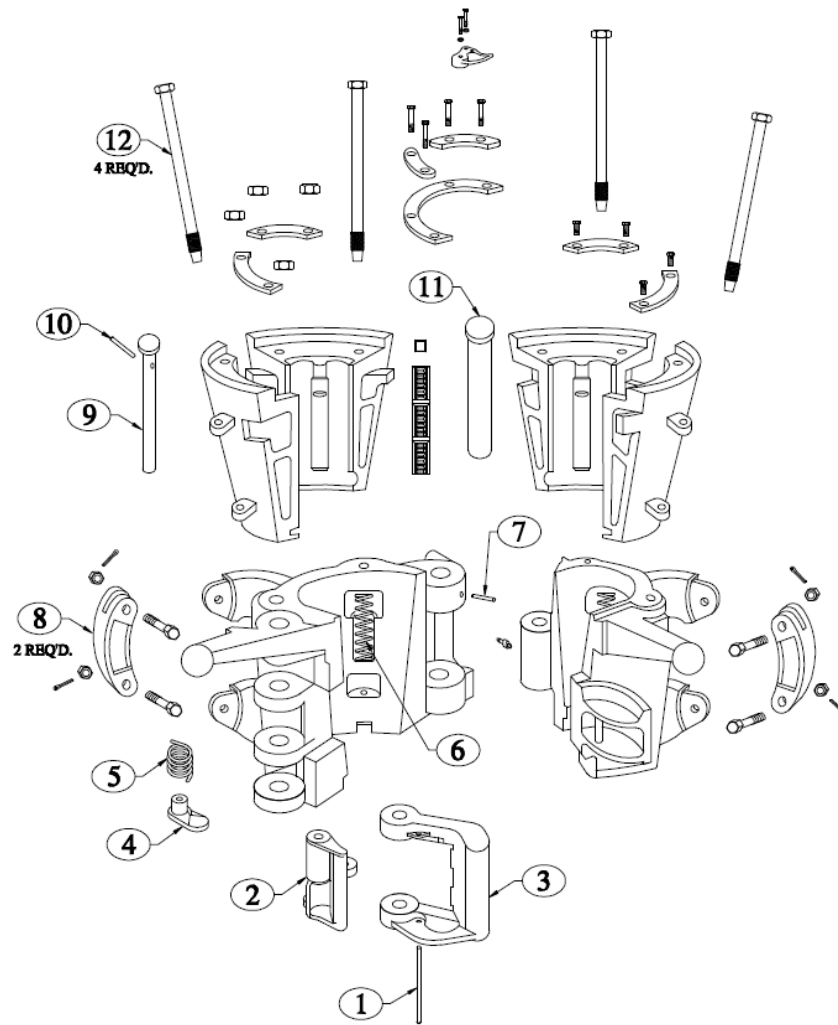

Figure 10 – YT exploded

YT Spare Parts List			
#	Component	Req	P/N
1	LATCH LOCK PIN	2	T13530
2	LATCH LOCK	1	T12972
3	LATCH	1	T15348
4	LATCH CAM	1	T12946
5	LATCH SPRING	1	T12978
6	SLIP SPRING	1	T23113
7	HINGE PIN RETAINER	2	T39253
8	LINK BLOCK	2	T9519
9	LATCH PIN	2	T24182
10	LATCH PIN RETAINER	2	T29464
11	HINGE PIN	1	T23116-1
12	SLIP BOLT	4	T23115-MOD

Table 9

Every Company has to have a Toolbox
at Texas International Oilfield Tools.

*We provide the tools to fuel the
world!*



The terms VARCO, VARCO-BJ, and BJ are trademarks of Varco I/P, Inc., National Oilwell Varco, L.P., or their affiliates. Texas International Oilfield Tools is not an authorized distributor of any Varco I/P or NATIONAL OILWELL VARCO product. Texas International Oilfield Tools is not affiliated with Varco I/P, Inc., National Oilwell Varco, L.P., or their affiliates. Varco I/P, Inc., National Oilwell Varco, L.P., and their affiliates do not endorse any Texas International Oilfield Tools' products or replacement parts.