



TI-CAThead Operation Manual

Document Number

OM010

REV	D	10/17/2024
-----	---	------------

© 2005-2025 Texas International Oilfield Tools, LTD.
Published by Texas International Oilfield Tools, LTD, Engineering
3035 Eastveld Dr • Houston, TX 77073
www.texasinternational.com

CONFIDENTIALITY STATEMENT

This document contains confidential information. All rights including copyright, confidential information, trade secrets and design rights are owned by Texas International Oilfield Tools, LTD (TIOT, Texas International, and Texas International Oilfield Tools). No use or disclosure is to be made without prior written permission of Texas International Oilfield Tools, LTD.

Revision History

Rev	Date	Reason
B	12/30/14	Re-Issued for Use
C	7/16/2020	Corrected BOM

Description of Change

Rev	Change
B	Reformatted and added Operation and Troubleshooting sections
C	Updated Table 3. Corrected Figure 4. Revised Table 10 by combining items 8 and 10 and on Table 12, qty of item 7 was 1. Revised Table 11: item 5 from 060000, 14 is now bought as an assembly (p/n T17567-16A) – see starred items in BOM, 15 was 040002, 17 was 060005, 20 was 060002, 36 was 030016, 40 was 030015, 42 was 030024, and added item 71. Revised Figure 21.

TABLE OF CONTENTS

GENERAL.....	4
CONVENTIONS	4
SAFETY.....	5
SPECIFICATIONS	5
HYDRAULIC FLUID.....	12
INSTALLATION	13
OPERATION.....	21
PREVENTIVE MAINTENANCE	21
TROUBLESHOOTING	23
STORAGE AND TRANSPORTATION	23
PARTS LIST	24
SPARE PARTS LIST	33

GENERAL



Figure 1

Texas International Oilfield Tools (TIOT) offers the TI-CAThead which operates manual tongs remotely and it is capable of providing a very high force pull. The hydraulic power unit runs the cylinder. The cylinder operates in conjunction with the cathead.

 Large forces are involved in using this device. Operate this equipment with extreme caution

 Ensure tongs are capable of safely handling the torque and pull loads applied. Follow normal safety rules working around wirelines under tension

CONVENTIONS



IMPORTANT SYMBOL IDENTIFICATION	
	WARNING to Operators / Users
	CAUTION to Operators / Users
 NOTE	NOTIFICATION to Operators / Users

Table 1

SAFETY

Texas International's equipment is used and installed in controlled rig environments involving hazardous operations and situations.

All personnel performing installation, operations, repair or maintenance on this TI-CAThead must have knowledge of rig procedure. All crew in the vicinity of operations should be trained on rig safety and tool operation.



If unusual noises are heard (pings or snaps) or if the tong movement is unusually slow, fast or jerky, cease operation of the TI-CAThead until the cause is determined and corrected

SPECIFICATIONS

Item	Bore	Stroke	Full stroke*	Max pull force	Max operating pressure	Piston area	Torque Range (ft/lbs)**	Weight (approx)
Cylinder	6"	24.5"	45"	35343 lbs	2500 psi	14.14 sq in	40 to 170,000	750 lbs

*wireline travel

**recommend verifying torque setting with a load cell

Table 2

Item	Motor	Internal Set Pressures		Max operating pressure	Reservoir Capacity (gallons)	Weight (approx)
		Main relief	Unloader			
Hydraulic Power Unit	10 hp	2750 psi	700 psi	2500 psi	30	800 lbs*

*dry

Table 3

Hydraulic Power Unit (HPU)		Amps
460 volts		12.8
230 volts		25.5
220 volts		31.3

Table 4

HPU Power frequency	Speed (rpm)	Pres-sure (psi)	Flow Rate (gpm)	Pres-sure (psi)	Flow Rate (gpm)
		Output		Output	
60 hz	1760	700	18.89	2500	4.73
50 hz	1445		15.51		3.88

Table 5

Specifications continued

TONG LENGTH		24"	30"	36"	42"	44"	48"	50"	54"	58"
PRESSURE, PSIG	PULL, LBS	TORQUE FT-LBS								
25	353	707	884	1060	1237	1296	1414	1473	1590	1708
50	707	1414	1767	2121	2474	2592	2827	2945	3181	3416
75	1060	2121	2651	3181	3711	3888	4241	4418	4771	5125
100	1414	2827	3534	4241	4948	5184	5655	5890	6362	6833
125	1767	3534	4418	5301	6185	6479	7069	7363	7952	8541
150	2121	4241	5301	6362	7422	7775	8482	8836	9542	10249
175	2474	4948	6185	7422	8659	9071	9896	10308	11133	11958
200	2827	5655	7069	8482	9896	10367	11310	11781	12723	13666
225	3181	6362	7952	9542	11133	11663	12723	13253	14314	15374
250	3534	7069	8836	10603	12370	12959	14137	14726	15904	17082
275	3888	7775	9719	11663	13607	14255	15551	16199	17495	18790
300	4241	8482	10603	12723	14844	15551	16964	17671	19085	20499
325	4595	9189	11486	13784	16081	16847	18378	19144	20675	22207
350	4948	9896	12370	14844	17318	18142	19792	20616	22266	23915
375	5301	10603	13253	15904	18555	19438	21206	22089	23856	25623
400	5655	11310	14137	16964	19792	20734	22619	23562	25447	27332
425	6008	12016	15021	18025	21029	22030	24033	25034	27037	29040
450	6362	12723	15904	19085	22266	23326	25447	26507	28627	30748
475	6715	13430	16788	20145	23503	24622	26860	27979	30218	32456
500	7069	14137	17671	21206	24740	25918	28274	29452	31808	34164
525	7422	14844	18555	22266	25977	27214	29688	30925	33399	35873
550	7775	15551	19438	23326	27214	28510	31101	32397	34989	37581
575	8129	16258	20322	24386	28451	29806	32515	33870	36579	39289
600	8482	16964	21206	25447	29688	31101	33929	35343	38170	40997
625	8836	17671	22089	26507	30925	32397	35343	36815	39760	42706
650	9189	18378	22973	27567	32162	33693	36756	38288	41351	44414
675	9542	19085	23856	28627	33399	34989	38170	39760	42941	46122
700	9896	19792	24740	29688	34636	36285	39584	41233	44532	47830
725	10249	20499	25623	30748	35873	37581	40997	42706	46122	49538
750	10603	21206	26507	31808	37110	38877	42411	44178	47712	51247
775	10956	21912	27390	32869	38347	40173	43825	45651	49303	52955
800	11310	22619	28274	33929	39584	41469	45238	47123	50893	54663
825	11663	23326	29158	34989	40821	42764	46652	48596	52484	56371
850	12016	24033	30041	36049	42058	44060	48066	50069	54074	58080
875	12370	24740	30925	37110	43295	45356	49480	51541	55664	59788
900	12723	25447	31808	38170	44532	46652	50893	53014	57255	61496
925	13077	26153	32692	39230	45769	47948	52307	54486	58845	63204
950	13430	26860	33575	40290	47006	49244	53721	55959	60436	64912
975	13784	27567	34459	41351	48243	50540	55134	57432	62026	66621
1000	14137	28274	35343	42411	49480	51836	56548	58904	63617	68329
1025	14490	28981	36226	43471	50716	53132	57962	60377	65207	70037
1050	14844	29688	37110	44532	51953	54427	59375	61849	66797	71745
1075	15197	30395	37993	45592	53190	55723	60789	63322	68388	73453
1100	15551	31101	38877	46652	54427	57019	62203	64795	69978	75162
1125	15904	31808	39760	47712	55664	58315	63617	66267	71569	76870
1150	16258	32515	40644	48773	56901	59611	65030	67740	73159	78578
1175	16611	33222	41527	49833	58138	60907	66444	69212	74749	80286

Table 6; Calibration

TONG LENGTH		24"	30"	36"	42"	44"	48"	50"	54"	58"
PRESSURE, PSIG	PULL, LBS	TORQUE FT-LBS								
1200	16964	33929	42411	50893	59375	62203	67858	70685	76340	81995
1225	17318	34636	43295	51953	60612	63499	69271	72158	77930	83703
1250	17671	35343	44178	53014	61849	64795	70685	73630	79521	85411
1275	18025	36049	45062	54074	63086	66090	72099	75103	81111	87119
1300	18378	36756	45945	55134	64323	67386	73512	76575	82701	88827
1325	18732	37463	46829	56195	65560	68682	74926	78048	84292	90536
1350	19085	38170	47712	57255	66797	69978	76340	79521	85882	92244
1375	19438	38877	48596	58315	68034	71274	77754	80993	87473	93952
1400	19792	39584	49480	59375	69271	72570	79167	82466	89063	95660
1425	20145	40290	50363	60436	70508	73866	80581	83938	90654	97369
1450	20499	40997	51247	61496	71745	75162	81995	85411	92244	99077
1475	20852	41704	52130	62556	72982	76458	83408	86884	93834	100785
1500	21206	42411	53014	63617	74219	77754	84822	88356	95425	102493
1525	21559	43118	53897	64677	75456	79049	86236	89829	97015	104201
1550	21912	43825	54781	65737	76693	80345	87649	91301	98606	105910
1575	22266	44532	55664	66797	77930	81641	89063	92774	100196	107618
1600	22619	45238	56548	67858	79167	82937	90477	94247	101786	109326
1625	22973	45945	57432	68918	80404	84233	91891	95719	103377	111034
1650	23326	46652	58315	69978	81641	85529	93304	97192	104967	112743
1675	23679	47359	59199	71038	82878	86825	94718	98664	106558	114451
1700	24033	48066	60082	72099	84115	88121	96132	100137	108148	116159
1725	24386	48773	60966	73159	85352	89417	97545	101610	109738	117867
1750	24740	49480	61849	74219	86589	90712	98959	103082	111329	119575
1775	25093	50186	62733	75280	87826	92008	100373	104555	112919	121284
1800	25447	50893	63617	76340	89063	93304	101786	106028	114510	122992
1825	25800	51600	64500	77400	90300	94600	103200	107500	116100	124700
1850	26153	52307	65384	78460	91537	95896	104614	108973	117691	126408
1875	26507	53014	66267	79521	92774	97192	106028	110445	119281	128117
1900	26860	53721	67151	80581	94011	98488	107441	111918	120871	129825
1925	27214	54427	68034	81641	95248	99784	108855	113391	122462	131533
1950	27567	55134	68918	82701	96485	101080	110269	114863	124052	133241
1975	27921	55841	69801	83762	97722	102375	111682	116336	125643	134949
2000	28274	56548	70685	84822	98959	103671	113096	117808	127233	136658
2025	28627	57255	71569	85882	100196	104967	114510	119281	128823	138366
2050	28981	57962	72452	86943	101433	106263	115923	120754	130414	140074
2075	29334	58669	73336	88003	102670	107559	117337	122226	132004	141782
2100	29688	59375	74219	89063	103907	108855	118751	123699	133595	143491
2125	30041	60082	75103	90123	105144	110151	120165	125171	135185	145199
2150	30395	60789	75986	91184	106381	111447	121578	126644	136775	146907
2175	30748	61496	76870	92244	107618	112743	122992	128117	138366	148615
2200	31101	62203	77754	93304	108855	114038	124406	129589	139956	150323
2225	31455	62910	78637	94364	110092	115334	125819	131062	141547	152032
2250	31808	63617	79521	95425	111329	116630	127233	132534	143137	153740
2275	32162	64323	80404	96485	112566	117926	128647	134007	144728	155448
2300	32515	65030	81288	97545	113803	119222	130060	135480	146318	157156
2325	32869	65737	82171	98606	115040	120518	131474	136952	147908	158865
2350	33222	66444	83055	99666	116277	121814	132888	138425	149499	160573
2375	33575	67151	83938	100726	117514	123110	134302	139897	151089	162281

Table 6; Calibration continued

Specifications continued

TONG LENGTH		24"	30"	36"	42"	44"	48"	50"	54"	58"
PRESSURE, PSIG	PULL, LBS	TORQUE FT-LBS								
2400	33929	67858	84822	101786	118751	124406	135715	141370	152680	163989
2425	34282	68564	85706	102847	119988	125702	137129	142843	154270	165697
2450	34636	69271	86589	103907	121225	126997	138543	144315	155860	167406
2475	34989	69978	87473	104967	122462	128293	139956	145788	157451	169114
2500	35343	70685	88356	106028	123699	129589	141370	147260	159041	170822

Table 6; Calibration continued

The torque calculation is based on the use of a thread compound containing 40 to 60% by weight of zinc, or 60% by weight of lead, applied thoroughly.

Size and Type of Connection	OD (in)	Bore of Drill Collars (in)							
		1	1-1/4"	1-1/2"	1-3/4"	2"	2-1/4"	2-1/2"	2-13/16"
API N. C. 23	3"	2500+	2500+	2500+					
	3-1/8"	3300+	3300+	2600					
	3-1/4"	4000	3400	2600					
2-7/8 P.A.C. (See Note 1)	3"		3800+	3800+	2900				
	3-1/8"		4900+	4200	2900				
	3-1/4"		5200	4200	2900				
2-3/8" API I.F. or API N.C. 26 or 2-7/8" Slim Hole	3-1/2"		4600+	4600+	3700				
	3-3/4"		5500	4700	3700				
2-7/8" Extra Hole or 3-1/2" Dbl. Streamline or 2-7/8" Mod Open	3-3/4"		4100+	4100+	4100+				
	3-7/8"		5300+	5300+	5300+				
	4-1/8"		8000+	8000+	7400				
2-7/8" API I.F. or API N.C. 31 or 3-1/2" Slim Hole	3-7/8"		4600+	4600+	4600+	4600+			
	4-1/8"		7300+	7300+	7300+	6800			
	4-1/4"		8800+	8800+	8100	6800			
	4-1/2"		10000	9300	8100	6800			
API N.C. 35	4-1/2"				8900+	8900+	8900+	7400	
	4-3/4"				12100	10800	9200	7400	
	5"				12100	10800	9200	7400	
3-1/2" Extra Hole or 4" Slim Hole or 3-1/2" Mod Open	4-1/4"				5100+	5100+	5100+	5100+	
	4-1/2"				8400+	8400+	8400+	8200	
	4-3/4"				11900+	11700	10000	8200	
	5"				13200	11700	10000	8200	
	5-1/4"				13200	11700	10000	8200	
3-1/2" API I.F. or API N.C. 38 or 4-1/2" Slim Hole	4-3/4"				9900+	9900+	9900+	9900+	8300
	5"				13800+	13800+	12800	10900	8300
	5-1/4"				16000	14600	12800	10900	8300
	5-1/2"				16000	14600	12800	10900	8300

Table 7; Recommended makeup torque

Size and Type of Connection	OD (in)	Bore of Drill Collars (in)							
		2"	2-1/4"	2-1/2"	2-13/16"	3"	3-1/4"	3-1/2"	3-3/4"
3-1/2" H-90 (See Note 2)	4-3/4"				8700+	8700+	8700+	8700+	8700+
	5"				12700+	12700+	12700+	12700+	10400
	5-1/4"				16900+	16700	15000	13100	10400
	5-1/2"				18500	16700	15000	13100	10400
4" Full Hole or API N.C. 40 or 4" Mod Open or 4-1/2" Dbl. Streamline	5"				10800+	10800+	10800+	10800+	10800+
	5-1/4"				15100+	15100+	15100+	14800	12100
	5-1/2"				19700+	18600	16900	14800	12100
	5-3/4"				20400	18600	16900	14800	12100
4" H-90 (See Note 2)	6"				20400	18600	16900	14800	12100
	5-1/4"					12500+	12500+	12500+	12500+
	5-1/2"					17300+	17300+	17300+	16500
	5-3/4"					22300+	21500	19400	16500
4-1/2" API Regular	6"					23500	21500	19400	16500
	6-1/4"					23500	21500	19400	16500
	5-1/2"					15400+	15400+	15400+	15400+
	5-3/4"					20300+	20300+	19400	16200
API N.C. 44	6"					23400	21600	19400	16200
	6-1/4"					23400	21600	19400	16200
	5-3/4"	20600+	20600+	20600+	18000				
	6"	25000	23300	21200	18000				
4-1/2" API Full Hole	6-1/4"	25000	23300	21200	18000				
	6-1/2"	25000	23300	21200	18000				
	5-1/2"	12900+	12900+	12900+	12900+	12900+			
	5-3/4"	17900+	17900+	17900+	17900+	17700			
4-1/2" Extra Hole or API N.C. 46 or 4" API I.F. or 5" Dbl. Streamline or 4-1/2" Mod Open	6"					17700			
	6-1/4"					19800			
	6-1/2"					17700			
	6-1/2"	27000	25000	22800	19800	17700			
4-1/2" H-90 (See Note 2)	6-1/2"	27000	25000	22800	19800	17700			
	5-3/4"		17600+	17600+	17600+	17600+			
	6"		23200+	23200+	22200	20200			
	6-1/4"		28000	25500	22200	20200			
4-1/2" H-90 (See Note 2)	6-1/2"		28000	25500	22200	20200			
	6-3/4"		28000	25500	22200	20200			
	5-3/4"		17600+	17600+	17600+	17600+			
	6"		23400+	23400+	23000	21000			
4-1/2" H-90 (See Note 2)	6-1/4"		28500	26000	23000	21000			
	6-1/2"		28500	26000	23000	21000			
	6-1/2"		28500	26000	23000	21000			
	6-3/4"		28500	26000	23000	21000			

Table 7; Recommended makeup torque continued

Specifications continued

Size and Type of Connection	OD (in)	Bore of Drill Collars (in)							
		2"	2-1/4"	2-1/2"	2-13/16"	3"	3-1/4"	3-1/2"	3-3/4"
5 H-90 (See Note 2)	6-1/4"		25000+	25000+	25000+	25000+			
	6-1/2"		31500+	31500+	29500	27000			
	6-3/4"		35000	33000	29500	27000			
	7"		35000	33000	29500	27000			
5-1/2" H-90 (See Note 2)	6-3/4"		34000+	34000+	34000+	34000			
	7"		41500+	40000	36500	34000			
	7-1/4"		42500	40000	36500	34000			
	7-1/2"		42500	40000	36500	34000			
5-1/2" API Regular	6-3/4"		31500+	31500+	31500+	31500+			
	7"		39000+	39000+	36000	33500			
	7-1/4"		42000	39500	36000	33500			
	7-1/2"		42000	39500	36000	33500			
4-1/2" API I.F. or API N.C. 50 or 5" Extra Hole or 5" Mod. Open or 5- 1/2" Dbl. Streamline	6-1/4"		22800+	22800+	22800+	22800+	22800+		
	6-1/2"		29500+	29500+	29500+	29500+	26500		
	6-3/4"		36000+	35500	32000	30000	26500		
	7"		38000	35500	32000	30000	26500		
	7-1/4"		38000	35500	32000	30000	26500		
5-1/2" API Full Hole	7"			32500+	32500+	32500+	32500+		
	7-1/4"			40500+	40500+	40500+	40500+		
	7-1/2"			49000+	47000	45000	41500		
	7-3/4"			51000	47000	45000	41500		
API N.C. 56	7-1/4"			40000+	40000+	40000+	40000+		
	7-1/2"			48500+	48000	45000	42000		
	7-3/4"			51000	48000	45000	42000		
	8"			51000	48000	45000	42000		
6-5/8" API Regular	7-1/2"			46000+	46000+	46000+	46000+		
	7-3/4"			55000+	53000	50000	47000		
	8"			57000	53000	50000	47000		
	8-1/4"			57000	53000	50000	47000		
6-5/8" H-90 (See Note 2)	7-1/2"			46000+	46000+	46000+	46000+		
	7-3/4"			55000+	55000+	53000	49500		
	8"			59500	56000	53000	49500		
	8-1/4"			59500	56000	53000	49500		
API N.C. 61	8"			54000+	54000+	54000+	54000+		
	8-1/4"			64000+	64000+	64000+	61000		
	8-1/2"			72000	68000	65000	61000		
	8-3/4"			72000	68000	65000	61000		
	9"			72000	68000	65000	61000		

Table 7; Recommended makeup torque continued

Size and Type of Connection	OD (in)	Bore of Drill Collars (in)							
		2"	2-1/4"	2-1/2"	2-13/16"	3"	3-1/4"	3-1/2"	3-3/4"
5-1/2" API I.F.	8"			56000+	56000+	56000+	56000+	56000+	
	8-1/4"			66000+	66000+	66000+	63000	59000	
	8-1/2"			74000	70000	67000	63000	59000	
	8-3/4"			74000	70000	67000	63000	59000	
	9"			74000	70000	67000	63000	59000	
	9-1/4"			74000	70000	67000	63000	59000	
6-5/8" API Full Hole	8-1/2"				67000+	67000+	67000+	67000+	66500
	8-3/4"				78000+	78000+	76000	72000	66500
	9"				83000	80000	76000	72000	66500
	9-1/4"				83000	80000	76000	72000	66500
	9-1/2"				83000	80000	76000	72000	66500
API N.C. 70	9"				75000+	75000+	75000+	75000+	75000+
	9-1/4"				88000+	88000+	88000+	88000+	88000+
	9-1/2"				101000+	101000+	100000	95000	90000
	9-3/4"				107000	105000	100000	95000	90000
	10"				107000	105000	100000	95000	90000
	10-1/4"				107000	105000	100000	95000	90000
API N.C. 77	10"					107000+	107000+	107000+	107000+
	10-1/4"					122000+	122000+	122000+	122000+
	10-1/2"					138000+	138000+	133000	128000
	10-3/4"					143000	138000	133000	128000
	11"					143000	138000	133000	128000
Connections with Full Face									
7" H-90 (See Note 2)	8"				53000+	53000+	53000+	53000+	
	8-1/4"				63000+	63000+	63000+	60500	
	8-1/2"				71500	68500	65000	60500	
7-5/8" API Regular	8-1/2"					60000+	60000+	60000+	60000+
	8-3/4"					71000+	71000+	71000+	71000+
	9"					83000+	83000+	79000	74000
	9-1/4"					88000	83000	79000	74000
	9-1/2"					88000	83000	79000	74000
7-5/8" H-90 (See Note 2)	9"					72000+	72000+	72000+	72000+
	9-1/4"					85500+	85500+	85500+	85500+
	9-1/2"					98000+	98000+	98000+	95500
8-5/8" API Regular	10"					108000+	108000+	108000+	108000+
	10-1/4"					123000+	123000+	123000+	123000
	10-1/2"					139000	134000	129000	123000

Table 7; Recommended makeup torque continued

Specifications continued

Size and Type of Connection	OD (in)	Bore of Drill Collars (in)							
		2"	2-1/4"	2-1/2"	2-13/16"	3"	3-1/4"	3-1/2"	3-3/4"
Connections with Full Face									
8-5/8" H-90 (See Note 2)	10-1/4" 10-1/2"					112500+ 128500+	112500+ 128500+	112500+ 128500+	112500+ 128500+
Connections with Low Torque Face									
7 H-90 (See Note 2)	8-3/4" 9"				67500+ 74000	67500+ 71000	66500 66500	62000 62000	
7-5/8" API Regular	9-1/4"					72000+	72000+	72000+	72000+
	9-1/2"					85000+	85000+	82000	77000
	9-3/4"					91000	87000	82000	77000
	10"					91000	87000	82000	77000
7-5/8" H-90 (See Note 2)	9-3/4"					91000+	91000+	91000+	91000+
	10"					105000+	105000+	103500	98000
	10-1/4" 10-1/2"					112500 112500	108000 108000	103500 103500	98000 98000
8-5/8" API Regular	10-3/4" 11"					112000+ 129000+	112000+ 129000+	112000+ 129000+	112000+ 129000+
	8-5/8" H-90 (See Note 2)	10-3/4" 11" 11-1/4"					92500+ 110000+ 128000+	92500+ 110000+ 128000+	92500+ 110000+ 128000+

Table 7; Recommended makeup torque continued



Do not exceed the system's rated pressure or over tighten fittings

HYDRAULIC FLUID

The power unit during operation heats the hydraulic fluid. If the reservoir temperature (seen in Figure 2) exceeds 150 degrees Fahrenheit, shut down the unit and let it cool. If this happens regularly, have unit repaired.



Be careful not to expose skin to hot hydraulic fluid – it can scald

The hydraulic fluid may be under pressures as high as 2500 psi. Fluid can be sprayed some distance, creating a slip hazard. If a leak occurs, shut down the power unit immediately and repair. Hydraulic fluid can irritate the skin – for skin contact, wash and rinse the affected area. If fluid comes in eye contact, use an emergency



Figure 2

eyewash or flush with saline solution. If not available, flush with distilled or lastly, tap water. Seek medical attention after flushing.



Avoid the hydraulic fluid spray– it can be injected through the skin at high pressures

Recommended Oils
Mobil DTE 24
Castrol Hyspin VG 32
Royal Purple Syndraulic 32
Shell Tellus 32
PetroCanada Environ AW 32
ISO viscosity grade 46*

* for warmer climates

Table 8

INSTALLATION

- 1) Location
 - 1a) find the right location(s) for the cylinder assembly and power unit
 - 1b) determine whether upright or inverted mounting is best in this application
 - 1c) build an appropriate bracing structure and install the cylinder
- 2) place the power unit, connect power, and make hydraulic connections to the cylinder and control box
- 3) install the wireline assembly
- 4) test the unit for proper operation

Locating the cylinder and power unit (1a) is a matter of function and safety. The cylinder, wireline and bracing should be aligned so that they will be in a straight line when the tong is at 90 degrees. While the cylinder will swivel on the backup post (and does in operation), the cylinder needs to start out aligned.

Installation continued

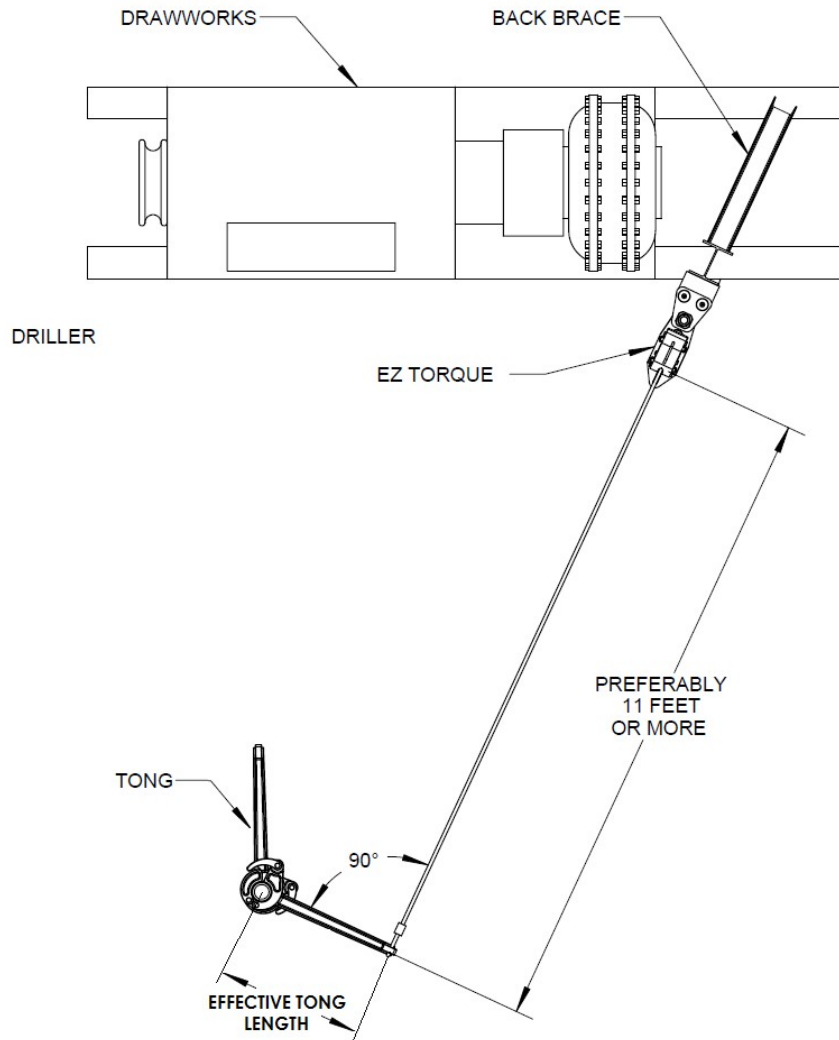

Figure 3

The longer the wireline is, the more efficient the cylinder will be – especially with shorter tongs. When the tong is at an angle other than 90 degrees the same line pull gives less torque. The wireline’s recommended minimum is eleven (11) feet.

The cylinder has a maximum pull of over 35,000 pounds of force. The cylinder location therefore must be tied to a structure capable of handling that force without damage or safety hazard. Drawworks skid beams are commonly used.

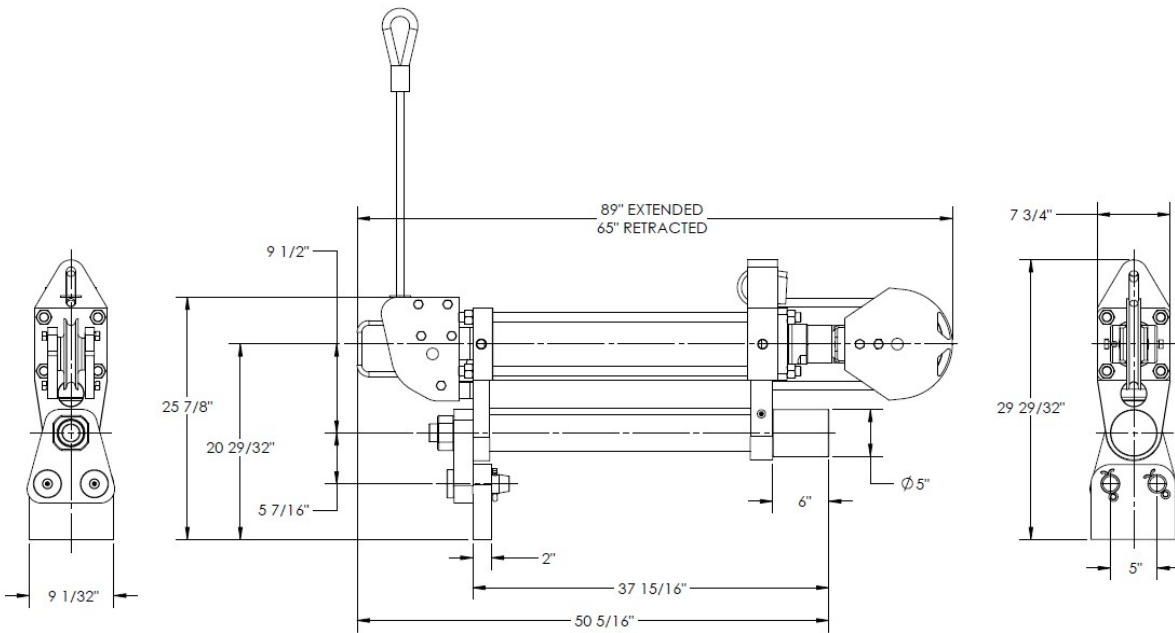

Figure 4: Cylinder dimensions

The cylinder extends 25". In the upright position, this typically requires a hole in the floor and no obstructions below. In the inverted position, clearance is needed overhead. The cable in either installation has to be at tong height. The upright position is preferred because it 1) takes the least space, 2) requires the least bracing material, 3) is easier to service, and 4) uses less connection hose. However, rig conditions may make the inverted installation more practical. The cylinder's supporting structure is not provided. See construction suggestions to follow.

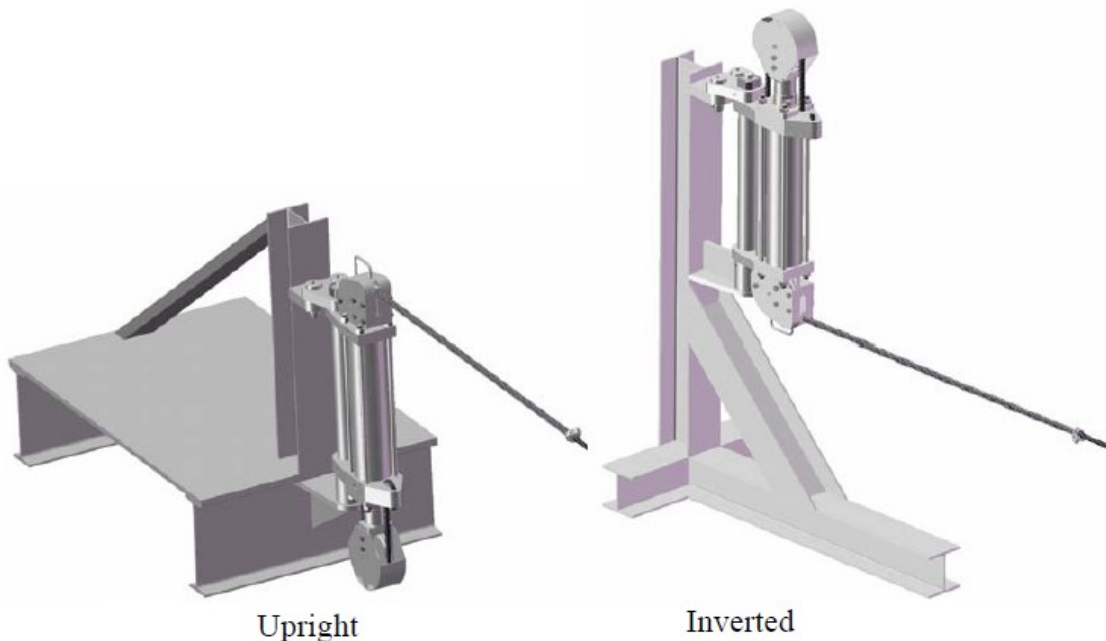

Figure 5: Cylinder installation

Installation continued

All bracing structure material (1c) should be ASTM A36 or better and should be easily weldable. Side bracing must be added to ensure cylinder is in a straight line. The supplied anchor adapter plate and backup post are suitable for welding to bracing material and drawworks skid beams.



Welding to be performed by a qualified welder, utilizing proper materials and technique. Failure to properly weld the anchor adapter plate, the backup post, or the bracing structure could lead to failure of the cylinder unit causing serious or fatal injury or property damage. TIOT does not take responsibility for faulty welds or improper bracing

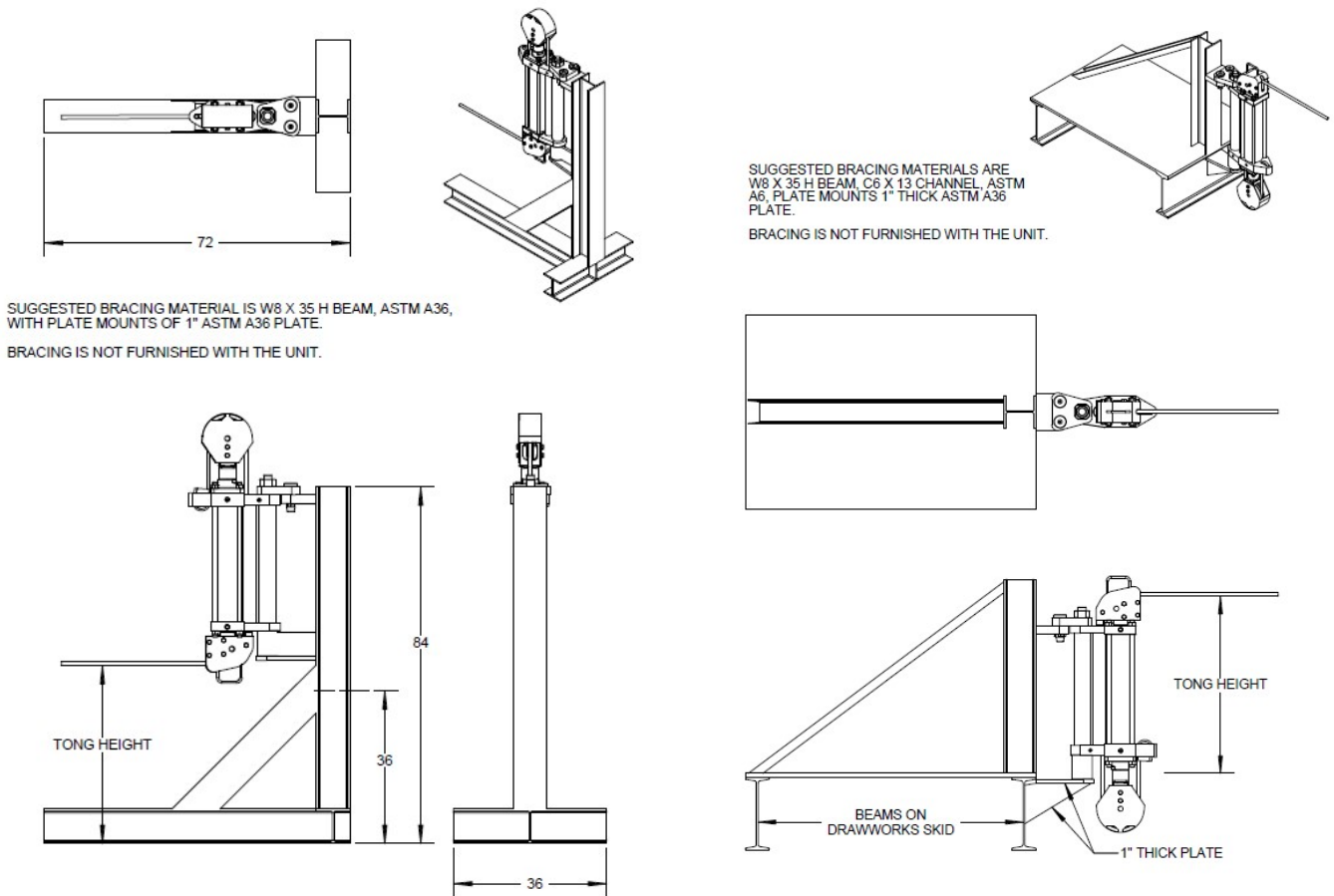

Figure 6; Typical installation

Slide the cylinder onto the backup post and install the top anchor plate and the two (2) pins (see Figure 7). Add the retaining nut and two (2) cotter keys. The retaining nut need not be super tight. Use a drop of Loctite ® or silicone sealer to keep it in place.

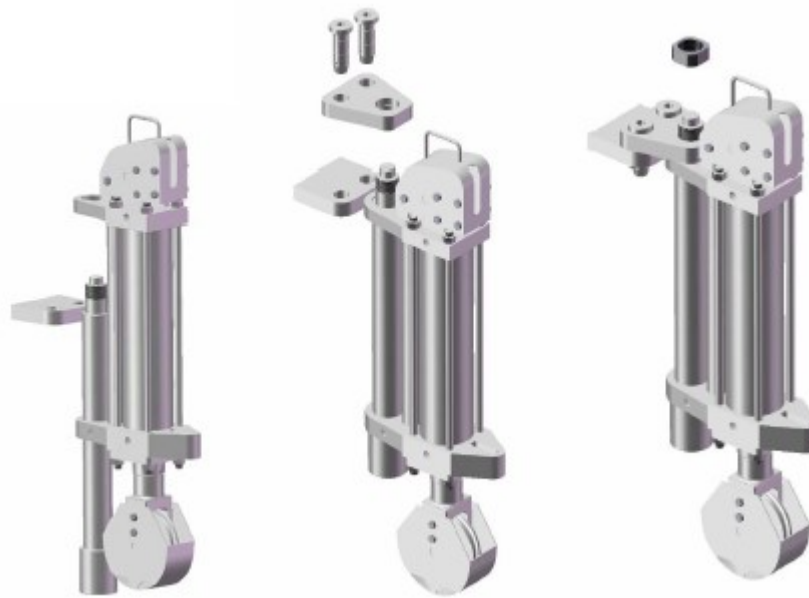

Figure 7

The hydraulic power unit requires three (3) phase 460 volts AC. The motor can be requested for 230/220 volts but 460 provides better performance. The hydraulic hoses to the cylinder can be lengthened to 50 feet without affecting cylinder operation, but the five (5) control hoses should remain at 25 feet as longer hoses will adversely affect cylinder reaction time. The top connections are for the control hoses, those on the side are for cylinder hoses. Electrical is connected through the top of the control box. The connections and control switch should be easy to reach. The fluid temperature gauge and filter condition



Figure 8; Power unit

indicator is on the opposite side and

will need to be seen and serviced. Mount the power unit (step #2) securely by either bolting or welding it to the rig floor. The unit requires ventilation and secure routing of the five (5) control hoses and two (2) cylinder hoses.



Figure 9

The control box should be mounted where 1) it's convenient to the driller and 2) the 25 foot control

Installation continued

hoses will reach. Connect A on the control box to the A on the hydraulic power unit, B to B, etc. See Figure 8.



Main breaker must be off and “locked out” until all wiring and wiring inspection is done. Wiring must be performed by a qualified, licensed electrician.

To connect power (step #2), remove the starter faceplate and install the power cord cable, attaching the three (3) leads to terminals L1, L2, and L3 as shown in Figure 9. Attach the ground wire to any grounded screw inside the starter enclosure.

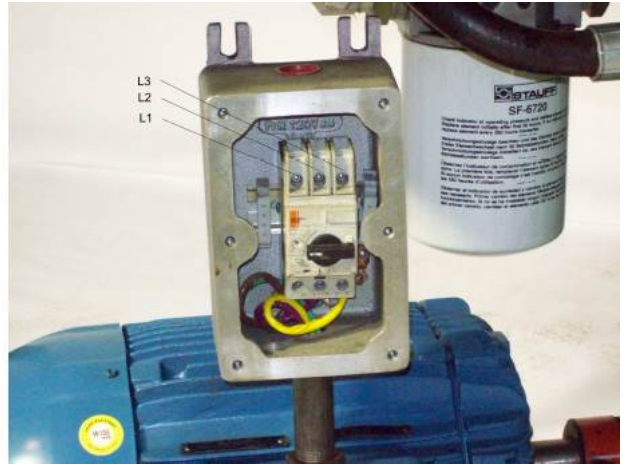

Figure 10



The green ground wire must ALWAYS be connected before power unit operation

Verify electrical connections and re-install starter faceplate. Remove lockouts and apply power. Verify counterclockwise pump rotation from the pump’s shaft end.

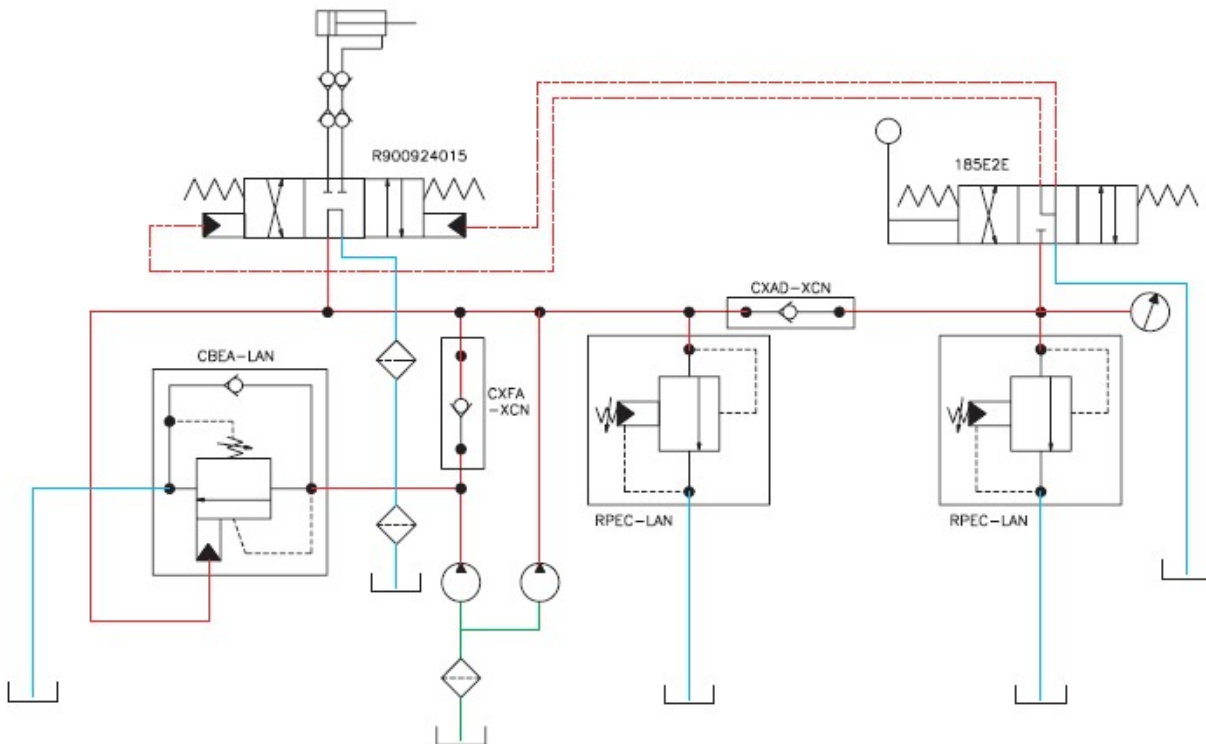

Figure 11: Hydraulic diagram

Install the wireline (step #3) as shown in Figure 12. 1) Attach the looped end of the wireline to the tongs. Slide a washer, the spring and then another washer onto the wireline and push them towards the loop end. Position the tong in the starting pull position (Figure 3).

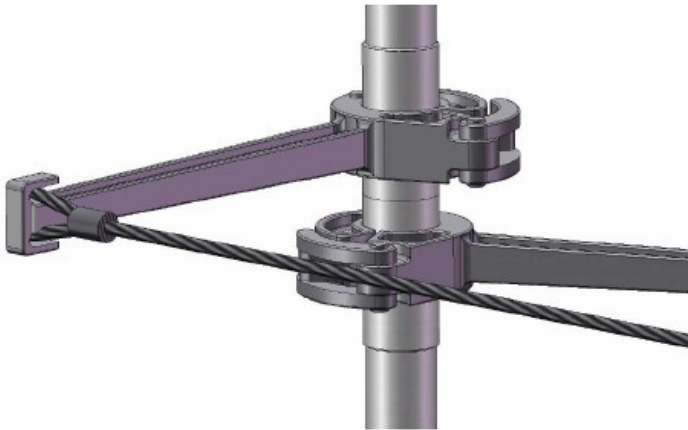

Figure 12

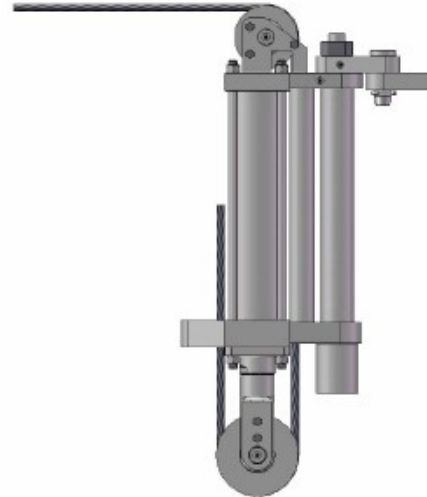

Figure 13



Be sure the cylinder is fully retracted

2) Remove both of the sheave guards. 3) Feed the line around the fixed end of the sheave (shown top in Figure 13), down through the wireline guide and around the rod end sheave and back up through the slot in the cylinder head. 4) Pull the line through to remove the slack. 5) Maintaining no slack in the line, form a loop as shown in Figure 13, feeding the slack end back through the cylinder head. 6) Place the wireline wedge in the loop and in the opening in the cylinder head (Figure 15) 7) Hold the tong in the



Figure 14



Figure 15; Wireline wedge inserted

Installation continued

start pull position and pull the dead end of the wireline as much as possible by hand, forcing the wedge further into the opening. 8) Replace the sheave guards. 9) Latch the tongs around the collars (or fasten the loop end of the line so it can't move) and activate the cylinder to pull the wedge tight into place. If the line length is less than eleven (11) feet, knock out the wedge and redo steps 6 through 8. 10) When the wireline is properly adjusted, excess cable can be cut off.

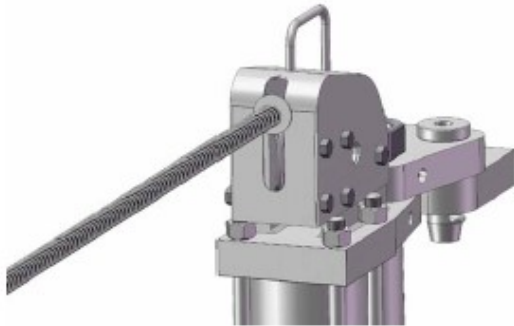

Figure 17: Push wireline spring



Figure 16

11) Push the wireline spring and washer up against the fixed sheave guard (Figure 17)
12) Compress the spring six (6) inches towards the cylinder and tighten the wireline clamp (Figure 18)

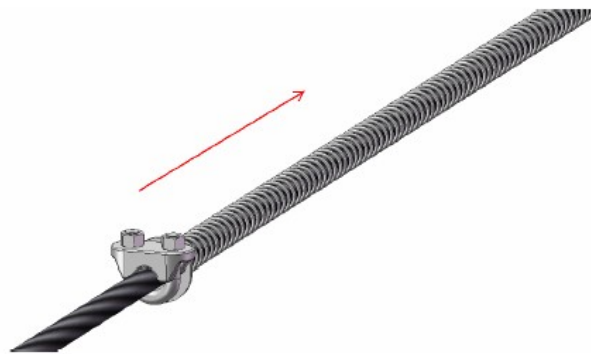

Figure 18: Compress spring

OPERATION

Once the hydraulic power unit is started, the operation of the cylinder is controlled by the control box. The lever is a spring return to center. Pushing the lever one direction will extend the cylinder (make up stroke) and pushing the lever in the opposite direction will retract the cylinder (reset).



Fully extend and retract the cylinder several times to purge air from the system

Set desired line pull using the calibration table (see Table 6) by determining the effective tong arm length (see Figure 3) and torque required for connections based on torque table (see Table 7). Figure the pressure setting for that torque (based on tong size). Extend and hold fully extended the cylinder with no load on the wireline. Turn the pressure adjusting knob until the pressure gauge reads the required pressure. Unit is now set.

PREVENTIVE MAINTENANCE



This is a suggested PM schedule. The tool owner has the responsibility to adjust the program according to actual tool usage



For hydraulic units, disconnect lines and drain system's pressure before maintenance.

Normal wear in course of use will eventually reduce the cylinder's capability. Cracks or the appearance of damage on the wireline can indicate the need for repair, even impending failure, and requires prompt attention.

Daily – While in use

- Apply EP 4 grease to prevent corrosion on wireline and grease fittings on cylinder
- Verify power unit and control box are in a secure and safe location
- Visually check wireline for broken wires, kinks, crushing, bird cages, corrosion, abrasion or any other abnormal condition – if found, replace
- Ensure wireline is routed so there no potential of 1) a pinching hazard and 2) anyone being trapped between the wireline and the rig structure

Preventative Maintenance continued

- Inspect the cylinder mounting for cracked welds, bent or distorted mounting components, excessive corrosion, leaks, worn hoses or connections, etc – if found, repair/replace
- Verify power cables and hydraulic hoses are not a trip hazard and cannot be pinched or cut
- Check for exposed wires and that electrical connections are secure
- Visually inspect the cylinder sheaves for excessive wear or abrasive material which damage the wireline
- Verify the sheaves rotate freely and sheave guards are in place and properly fastened to the cylinder
- Check cylinder for hydraulic fluid leaks – correct before operating
- Visually check cylinder rod (unpainted chromed surface) for damage (dings or burrs) that could damage the bearing or internal seals – if found, pull from operation, and replace
- Keep the power unit exterior clean of oil, dust, dirt, water, or chemicals
- Verify the hydraulic fluid level in the reservoir – fill as needed



Wireline is sharp. Wireline should not be checked by running a hand, gloved or not, over the surface.

Quarterly

- Replace filter or earlier if the filter's indicator gauge shows a dirty element (before needle is in the red). Gauge and filter are shown in Figure 19.
- Change the hydraulic fluid every three (3) to six (6) months – see recommended fluid on Table 8. Clean diffuser and strainer by rinsing with solvent and drying. If cleaning is not effective, replace



Figure 19

TROUBLESHOOTING

Failure Mode	Possible Cause	Possible Solution
Motor will not run	Connections	Verify wiring connections
		Check voltage (460)
	Circuit breaker tripped	Reset/Overload
	Starter coil	Check continuity
System pressure will not build up	Motor	Replace
	Leak	Check hoses and fittings
	Pump	Verify counterclockwise rotation
Check pump to motor coupling		
Cylinder speed slow	Relief valve	Adjust or replace
	Obstruction in flow line	Depressurize and drain. Check hoses
Cylinder will not extend or retract	Cylinder rod damaged	Check for burrs, galls, or bent conditions
	Control hoses	Verify connections
	Obstruction in flow line	Depressurize and drain. Check hoses
	Pump worn out	Replace

Table 9

STORAGE AND TRANSPORTATION

- Prevent excessive exposure to water and moisture
- Clean the tool after use - steam clean as needed; remove mud, debris, and any other substances
- For long term storage, depressurize the system and flush hydraulic fluid

PARTS LIST

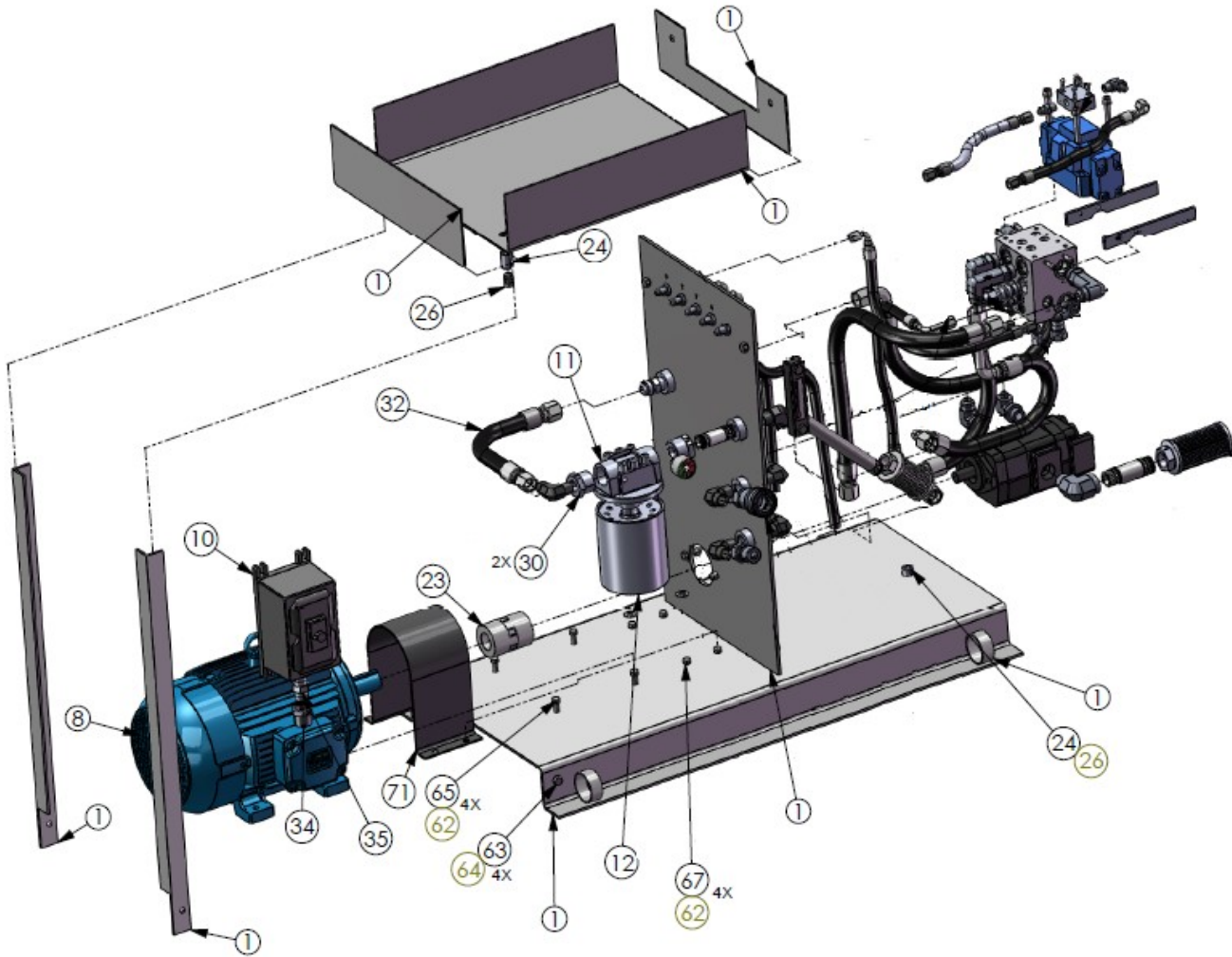

Figure 20

#	Component	Qty	P/N
1	TI-CAThead POWER SUPPLY CHASSIS & TANK	1	T17567-01
8	MOTOR & STARTER	1	070005
10			
11	FILTER BASE	1	T37042-01
12	FILTER	1	T37042-02
23	COUPLING ASSEMBLY (MOTOR TO PUMP)	1	T17567-40
24	COUPLING	2	030022
26	PLUG	2	030000
30	BUSHING, PIPE, HEX REDUCER	2	030010
32	HOSE	1	050017
34	BUSHING, PIPE, HEX REDUCER	1	030001
35	HEX PIPE NIPPLE	1	T12460-36
62	NUT, HEX	8	040001
63	NUT, HEX	2	040004
64	SCREW, CAP, HEX HEAD	2	040003
65	SCREW, CAP, HEX HEAD	4	040000
67	SCREW, CAP, HEX HEAD	4	040050
71	MOTOR SHAFT AND COUPLING GUARD	1	T17567-01-13

Table 10 : Figure 20 BOM

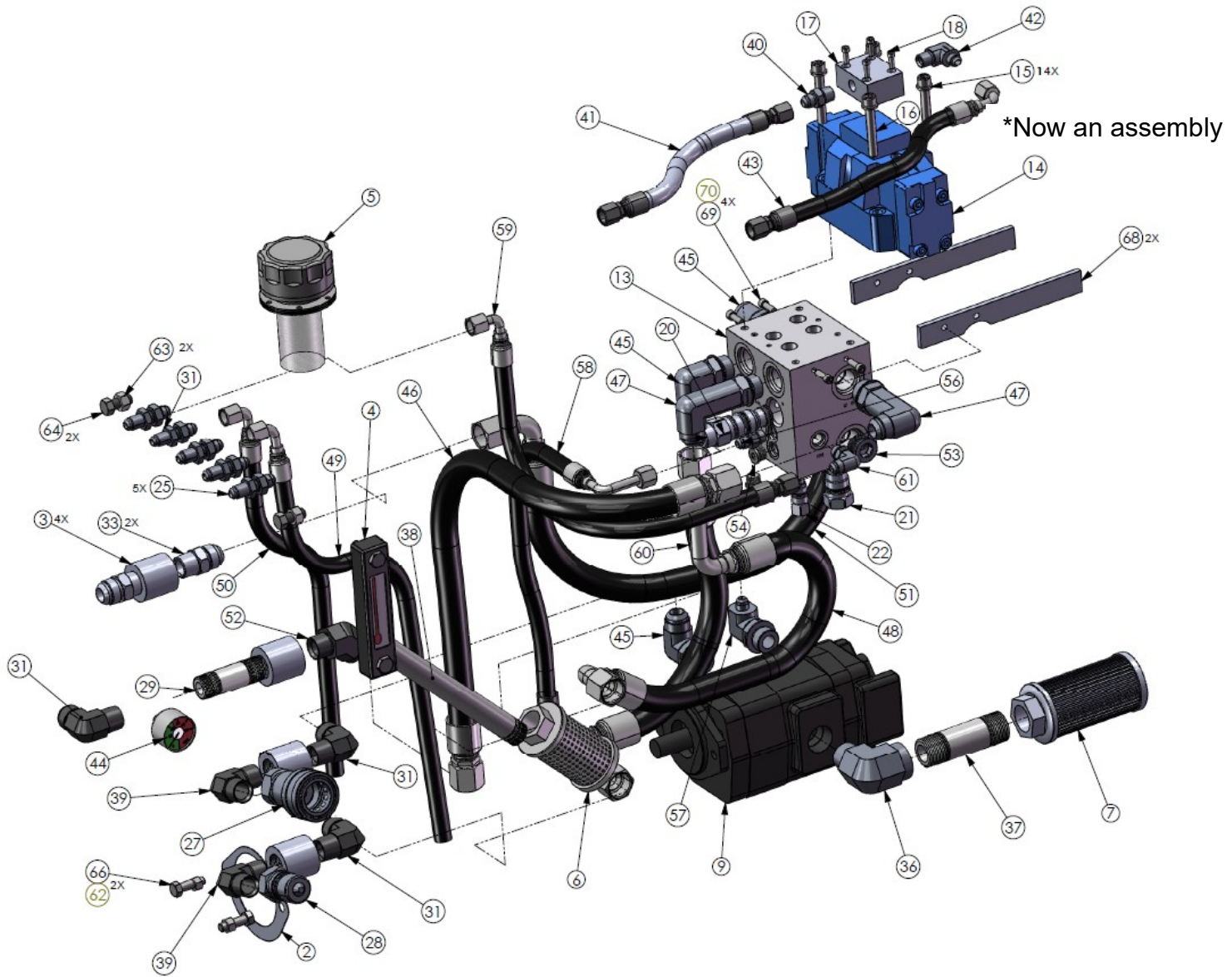

Figure 21

#	Component	Qty	P/N
2	PUMP GASKET	1	T17567-29
3	COUPLING, PIPE, STEEL	4	030021
4	SIGHT LEVEL GAUGE/TEMP	2	T17567-39
5	FILLER CAP/FILLER BREATHER	1	T17567-38
6	DIFFUSER	1	T17567-10
7	STRAINER, SUCTION	1	060011
9	TANDEM PUMP	1	T17567-46
13*	MANIFOLD	1	060001
14*	VALVE	1	T17567-16

*COMPONENTS OF NEW ASSEMBLY T17567-16A

Table 11: Figure 21 BOM

#	Component	Qty	P/N
15	WASHER, LOCK, SPLIT	4	040095
16*	SCREW, CAP, SOCKET HEAD	4	040008
17*	PILOT CONNECTION BLOCK	1	060005-1
18*	SCREW, CAP, SOCKET HEAD	4	040009
20*	COUNTERBALANCE VALVE	1	060002
21	CHECK VALVE	1	060003
22	CHECK VALVE	1	060004
25	UNION, BULKHEAD	5	030013
27	QUICK COUPLING (FEMALE)	1	T12460-37
28	QUICK COUPLING (MALE)	1	T12460-40
29	NIPPLE, PIPE	1	030009
31	ELBOW	3	030011
33	CONNECTOR, STRAIGHT, STEEL	2	030014
36	ELBOW, STREET	1	030131
37	NIPPLE, PIPE	1	030017
38	NIPPLE, PIPE	1	030057
39	ELBOW	2	030012
40	CONNECTOR	1	030256
41	HOSE	1	050008
42	ELBOW	1	030255
43	HOSE	1	050007
44	GAGE	1	060006
45*	ELBOW	3	030018
46	HOSE	1	050013
47*	ELBOW	2	030005
48	HOSE	1	050015
49	HOSE	1	050009
50	HOSE	1	050010
51	HOSE	1	050014
52	ELBOW	1	030008
53	PLUG	1	030004
54	PLUG	1	030003
56	CONNECTOR	1	030019
57	ELBOW	1	030020
58	HOSE	1	050012
59	HOSE	1	050011
60	CONNECTOR	1	050016
61	ELBOW	1	030052

*COMPONENTS OF NEW ASSEMBLY T17567-16A

Table 11: Figure 21 BOM continued

#	Component	Qty	P/N
62	NUT, HEX	2	040001
63	NUT, HEX	2	040004
64	SCREW, CAP, HEX HEAD	2	040003
66	SCREW, CAP, HEX HEAD	2	040016
68	MAIN VALVE BLOCK BRACKET	2	T17567-01-10
69	SCREW, CAP, SOCKET HEAD	4	040006
70	WASHER, LOCK	4	040007
71	PLUG	1	030002

Table 11: Figure 21 BOM continued

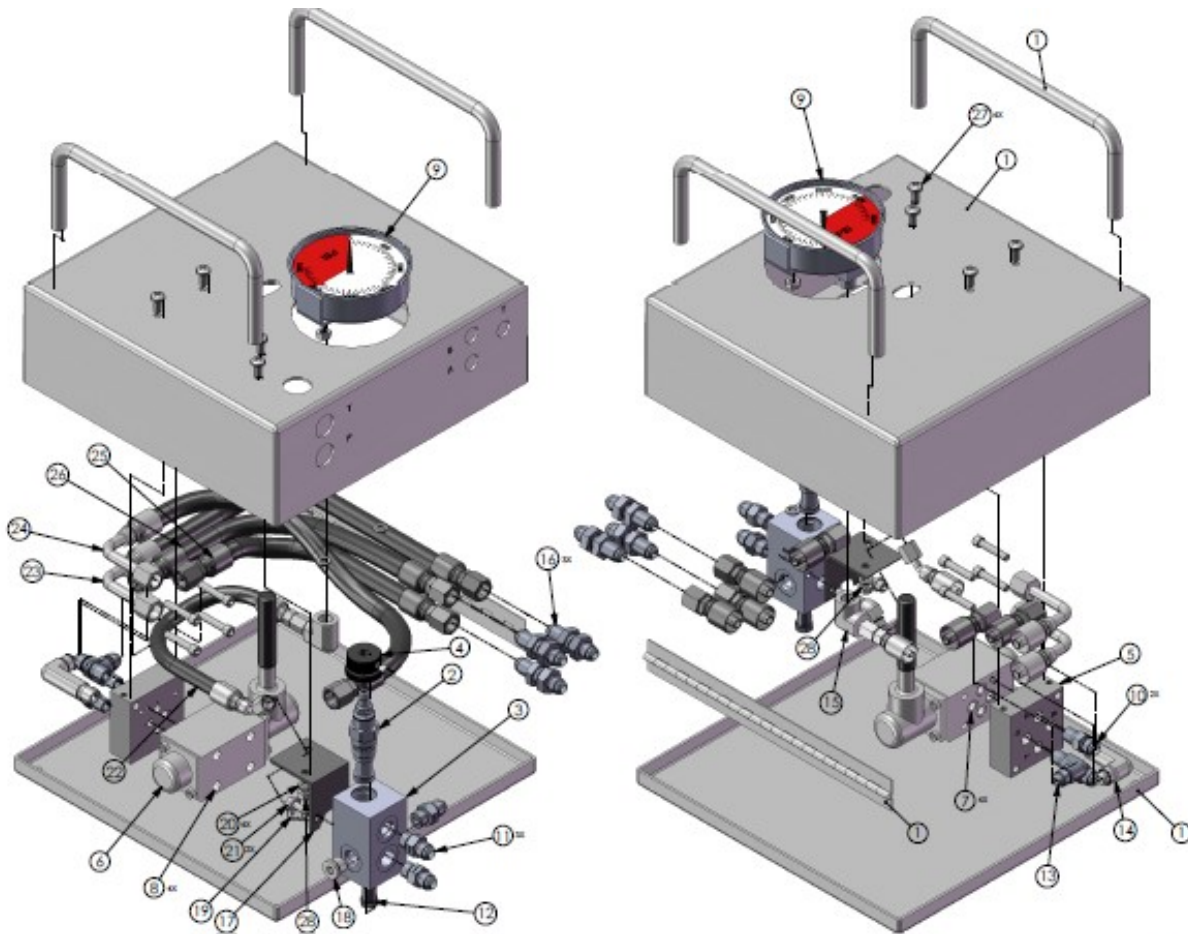

Figure 22

#	Component	Qty	P/N
1	REMOTE CONTROL MODULE HOUSING	1	T17567-33
2	RELIEF VALVE	1	060041
3	BODY, LINE MOUNT	1	060007
4	RELIEF VALVE KNOB KIT	1	060008
5	CONTROL VALVE SUBPLATE	1	060009
6	CONTROL VALVE	1	060010
7	O-RING	4	020001
8	SCREW, CAP	4	040010
9	TI-CAThead GAUGE 0-5000 PSI	1	T17567-34
10	CONNECTOR	2	030015
11	CONNECTOR, STRAIGHT	3	030019
12	PLUG, PIPE	1	030000
13	ELBOW	1	030024
14	ELBOW	1	030025
15	ELBOW	1	030026
16	UNION, BULKHEAD	3	030013
17	BRACKET, RELIEF VALVE	1	T17567-48
18	PLUG	1	030003
19	ELBOW	1	030145
20	WASHER, LOCK	4	040007
21	SCREW, CAP, SOCKET HEAD	2	040006
22	HOSE	1	050002
23	HOSE	1	050005
24	HOSE	1	050008
25	HOSE	1	050003
26	HOSE	1	050007
27	SCREW, PAN HEAD	4	040103
28	NUT, HEX	2	040104

Table 12; Control box BOM

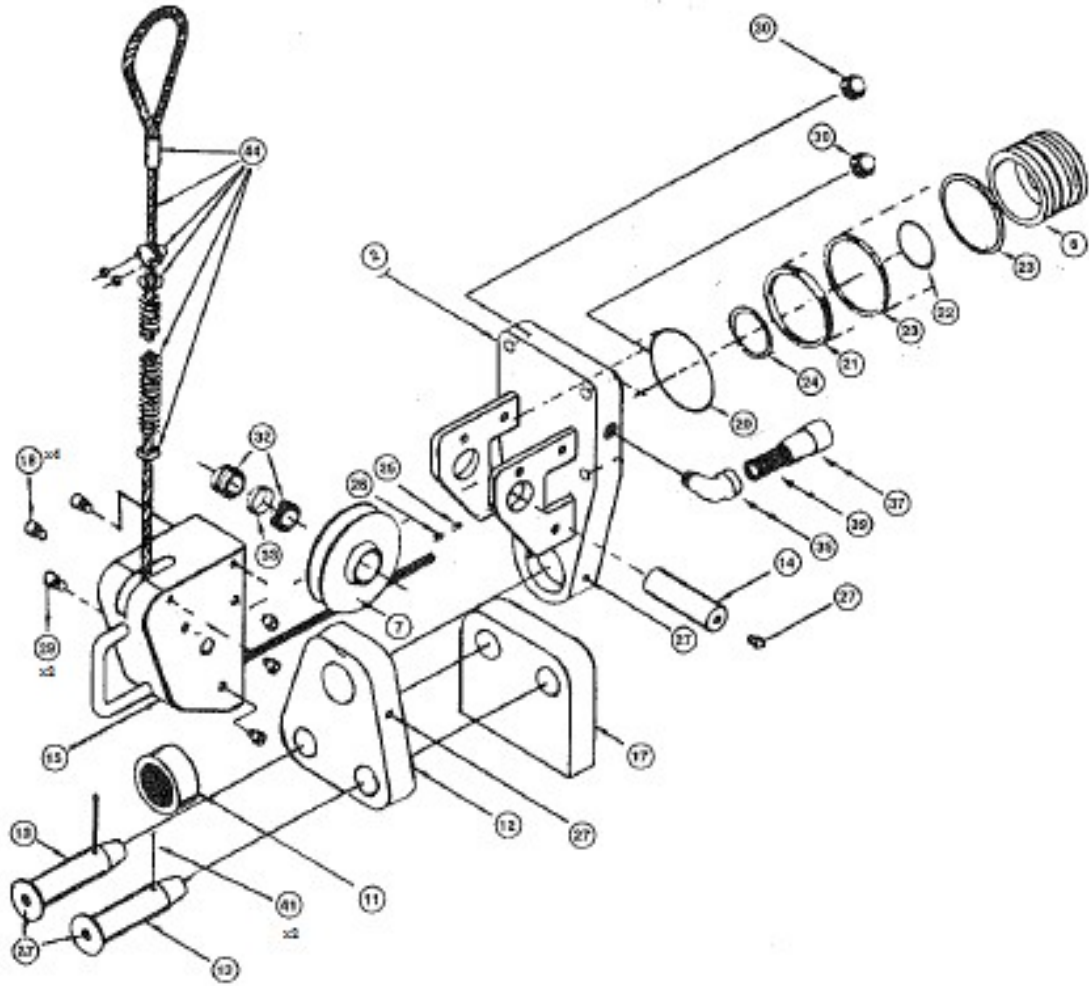

Figure 23

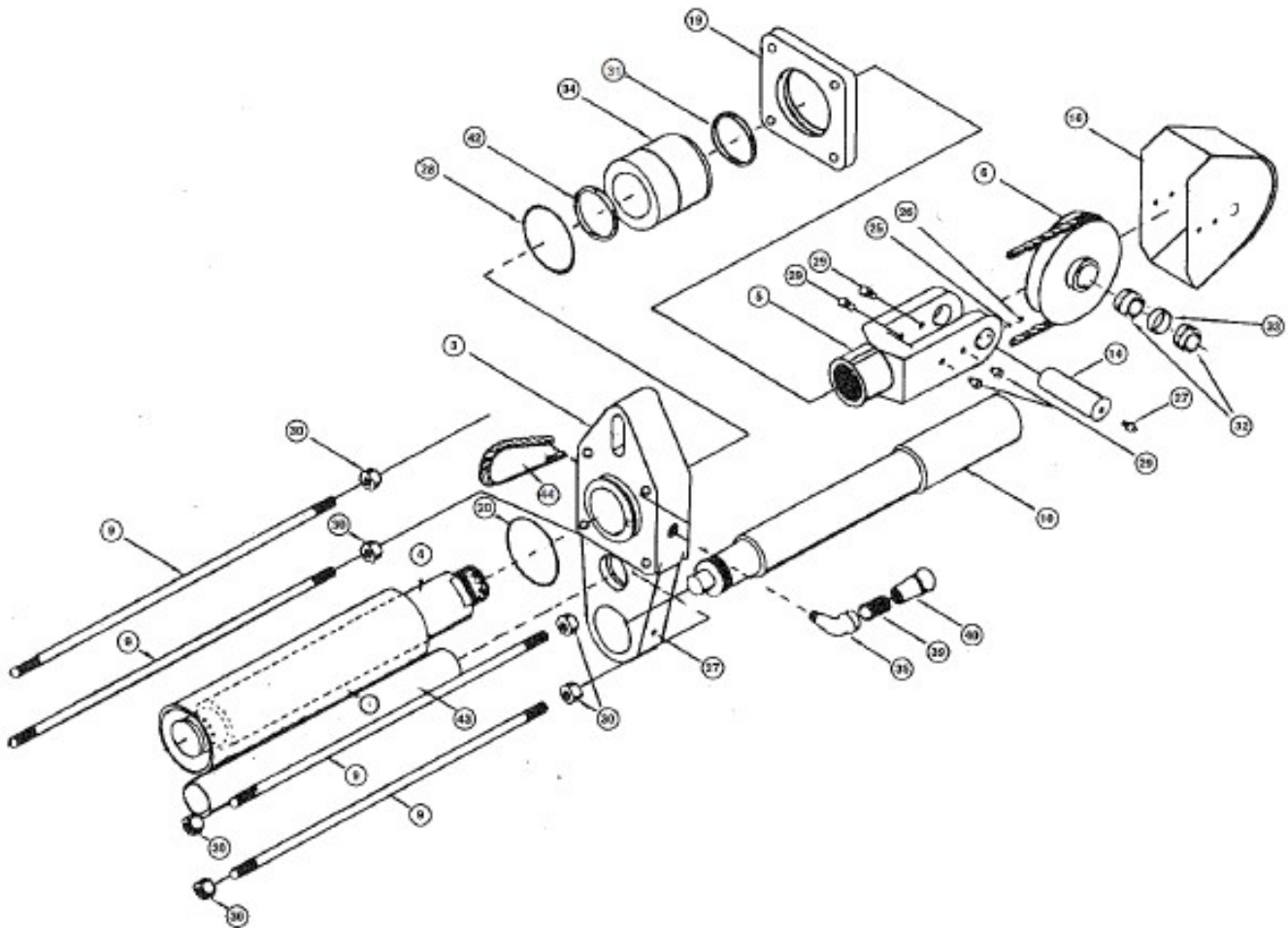

Figure 23 continued

#	Component	Qty	P/N
1	Cylinder Tube	1	T22427
2	Cylinder Head - Blind End	1	T12460-02
3	Cylinder Head - Rod End	1	T17572
4	Piston Rod	1	T22425
5	Yoke Piston Rod	1	T12460-05
6	8" Sheave	1	T12460-44
7	6" Sheave	1	T12460-45
8	Piston	1	T17571
9	Tie Rod Cylinder	4	T22428
10	Back-up Post	1	T22426
11	Retaining Nut - Anchor Adapter	1	T12460-11
12	Anchor Adapter	1	T12460-12
13	Pin Anchor Adapter	2	T12460-13
14	Shaft - Sheave	2	T12460-51
15	Guard - Fixed Sheave	1	T12460-15

Table 13: Figure 23 & 24 BOM

Parts List continued

#	Component	Qty	P/N
16	Guard - Rod Sheave	1	T12460-16
17	Anchor Adapter	1	T12460-17
18	Cap Screws	4	040021
19	Retainer Plate	1	T17569
20	O Ring (w/Back up Ring)	2	T12460-20
21	Rider Ring (Piston)	1	T17568-01
22	Piston I.O. Seal (O-Ring)	1	T17568-02
23	Piston U Cup	2	T12460-47
24	Truarc Retainer Ring	1	T12460-24
25	Half Dog Headless Setscrew	2	040033
26	Headless Setscrew	2	T12460-26
27	Alemite Grease Fitting	7	080013
28	Cartridge OD Seal	1	T17568-03
29	Cap Screws	10	040175
30	Nuts - Tie Rod	8	T12460-30
31	Backup Ring	2	T17568-03-2
32	Roller Bearing	4	T12460-32
33	Spacer	2	T12460-33
34	Rod Bearing Cartridge	1	T17570
35	Street Elbow	2	030191
37	Quick Coupling	1	T12460-37
39	All Thread Nipple	2	030096
40	Quick Coupling, Male	1	T12460-40
41	Cotter Pin	2	080020
42	Rod Seal	1	T17568-04
43	Wireline Guide	1	T22492
44	Wireline Assembly	1	T22488
45	Rod Wiper	1	T17568-05

Table 13: Figure 23 & 24 BOM continued

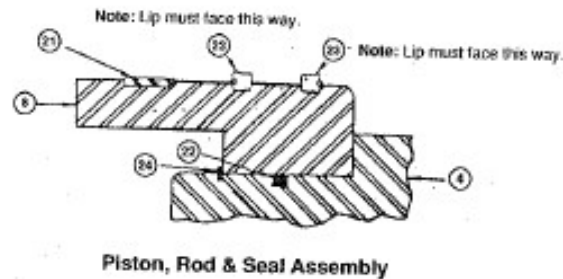

Figure 24

SPARE PARTS LIST

Parts adequate for one (1) year of normal intended use if oil is kept clean. Replace the filter before filter indicator moves into the red zone. Drain and replace fluid whenever it is discolored, cloudy, dirty, or has overheated.

Component	Req	P/N
TI-CAThead Cylinder Seal Kit (all cylinder seals)	1	T17568-07
TI-CAThead Power Unit / Control Box Spares Kit	1	T17567-50
Wireline	1	T22488

Table 14

Every Company has to have a Toolbox.

At Texas International Oilfield Tools,

we provide the tools to fuel the world!



The terms VARCO, VARCO-BJ, and BJ are trademarks of Varco I/P, Inc., National Oilwell Varco, L.P., or their affiliates. Texas International Oilfield Tools is not an authorized distributor of any Varco I/P or NATIONAL OILWELL VARCO product. Texas International Oilfield Tools is not affiliated with Varco I/P, Inc., National Oilwell Varco, L.P., or their affiliates. Varco I/P, Inc., National Oilwell Varco, L.P., and their affiliates do not endorse any Texas International Oilfield Tools' products or replacement parts.